

road sections

- 3.1 Design tools
- 3.2 Segregation or integration
- 3.3 Possible cycle facilities along road sections
- 3.4 Physical segregation
- 3.5 Different means of physical segregation
- 3.6 Contra-flow cycle tracks
- 3.7 On-road cycle tracks
- 3.8 Contra-flow on-road cycle tracks
- 3.9 Carriageway width for mixed traffic use
- 3.10 Cyclists and pedestrians only



Segrated Cycle Facility and Exit Construction (Holland)

3.1 Design tools

3.1.1 Space required for a cyclist

- The width of the track surface is based on a deviation of 0.25m. This is standard for cycling speeds up to 11 km/hour.
- The deviation path of a cyclist is at a minimum when the cycling speed is near to 20 km/hour.
- When the cycling speed is less than 11km/hour more space for deviating must be provided. For example when cyclists are approaching traffic lights.
- The length of a bicycle is 2.00m.
- The width of a stopped cyclist is 0.75m.

The minimum amount of space needed by cyclists in different situations is shown in figures 3.1 and 3.2.

Height restriction

Figure 3.2 shows that the minimum headroom required for cyclists in subways, or under road signs, is 2.50m.

FIGURE 3.1 | PROFILE OF A CYCLIST

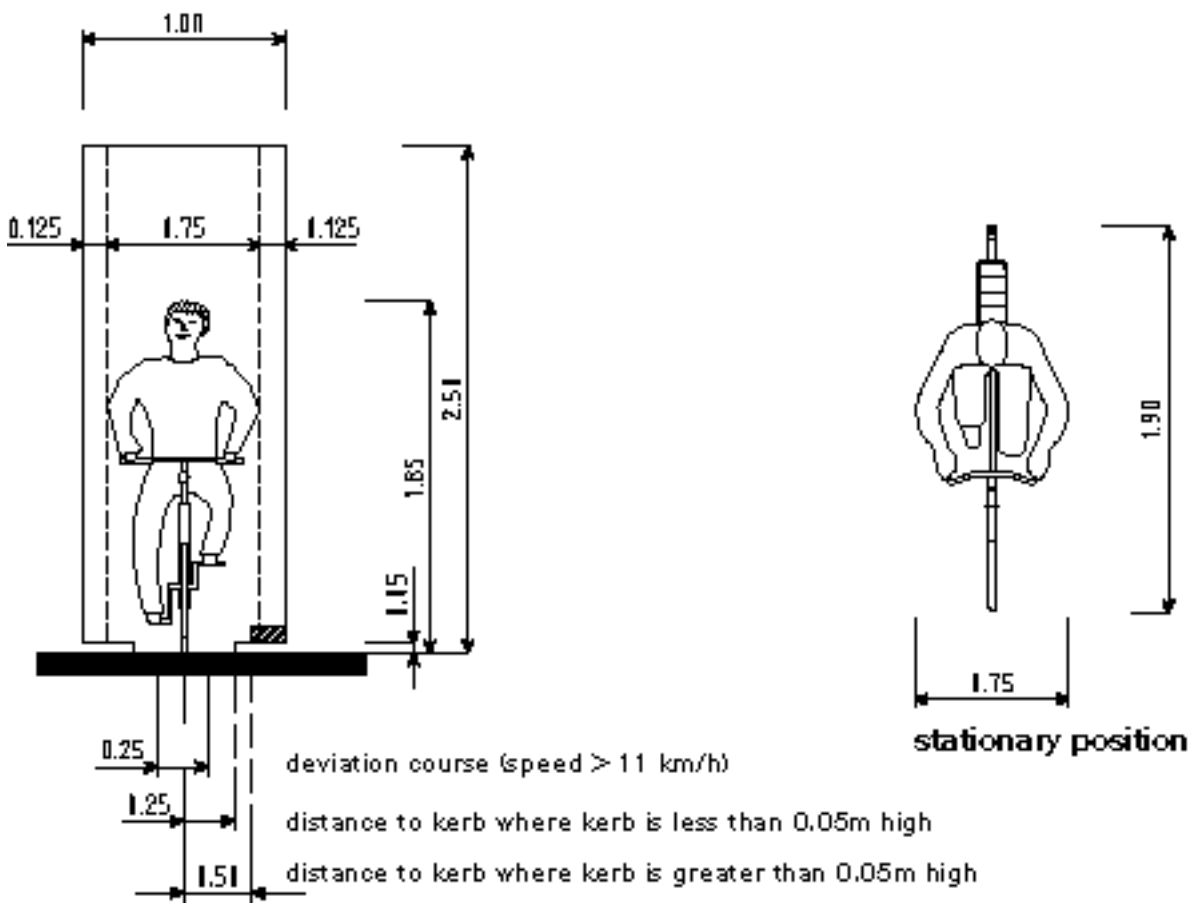
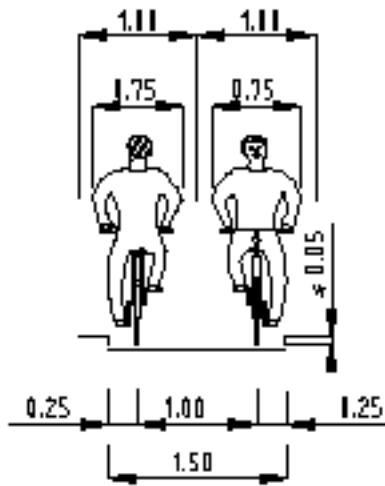
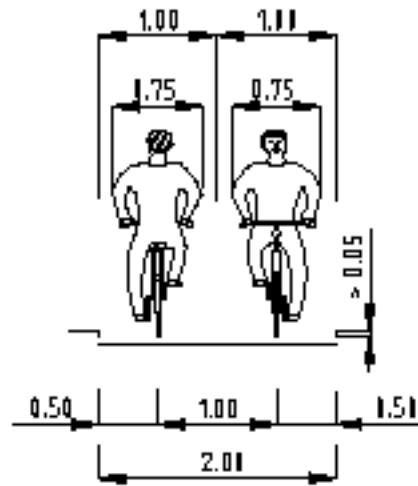

FIGURE 3.2 | THE MINIMUM AMOUNT OF SPACE NEEDED BY CYCLISTS IN DIFFERENT SITUATIONS



where kerb is $\leq 0.05\text{m}$



where kerb is higher than 0.05m

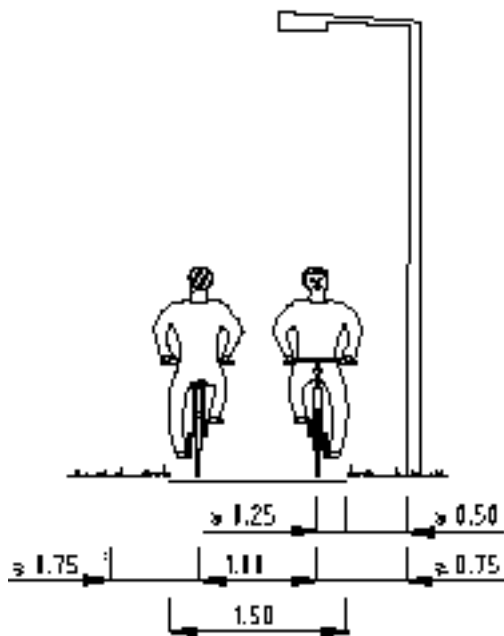

- in relation to objects (lamp-posts, road signs, trees etc.)

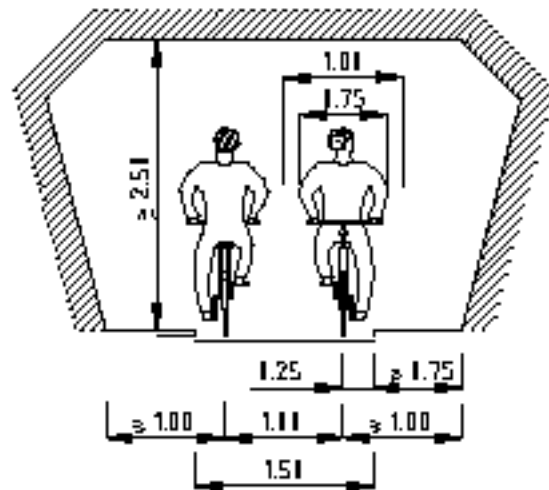

- in relation to solid walls (frontages, etc.)

3.1.2 Gradients (fig 3.3)

Ascending:

- for short rises (height difference up to 10m) the lowest section can be designed with a steeper gradient after which the higher section should be designed with a flatter gradient. (see vertical alignment situation A). This helps the cyclist climb the gradient at a more constant speed;
- for long gradients (height differences of more than 10m) after every climb of 5m height difference, a horizontal section of approximately 25m will help to make the climb easier for cycle traffic (see vertical alignment situation B);
- take into consideration the influence of the wind, and cover from vegetation.

Descending:

- roads should be designed so the descent speed of cyclists can be controlled, unless the gradient ends with a long level stretch. Areas of a level track should be used to assist cyclists to reduce their speed on a descent;
- at the base of a gradient greater than 2% it is desirable to have a horizontal section of at least 5m in advance of traffic lights or a junction.
- sharp bends on, or at the base of a gradient, should be avoided;
- necessary control devices should be placed on the gradient of slopes, to prevent cyclists building up high speeds. For example, the provision of 5m sections of level track at intervals is effective.

FIGURE 3.3 | VERTICAL ALIGNMENT SITUATION A AND SITUATION B

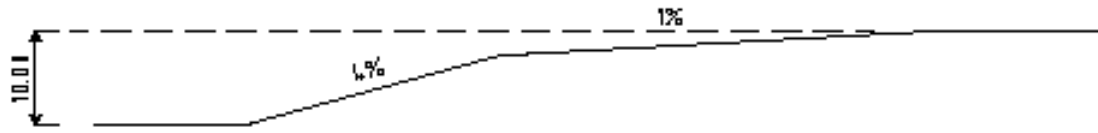

Vertical alignment situation A

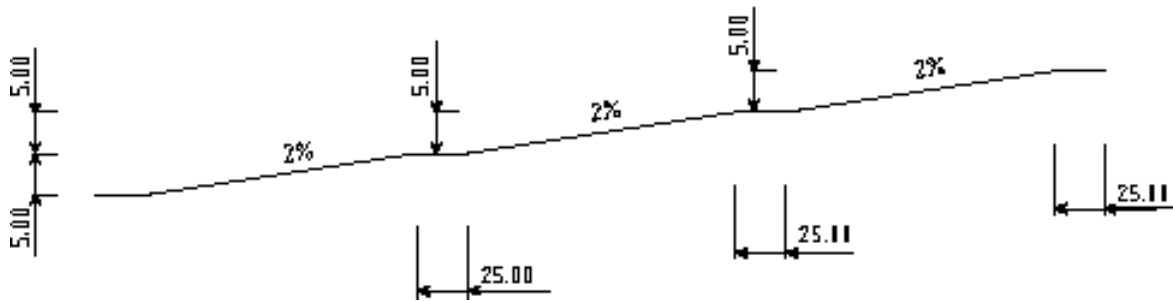

Vertical alignment situation B

3.2 Segregation or integration?

The decision to segregate cycle traffic from motorised traffic depends on the speed and volume of the motor vehicles. The volume of cycle traffic determines the dimensions and the type of facilities.

Figure 3.4 shows the result of an investigation conducted by SWOV (the Dutch Institute for Road Safety Research). This figure can be used to obtain a rough estimation of the type of segregation needed in relation to different combinations of speed and volume. The lines in the illustration indicate the broad separation areas and are not strict separation lines.

Note: The volume of cycle traffic is not a central factor in deciding whether a segregated cycle track is needed or not. As the SWOV report stated, the potential danger is not caused by cycle traffic. Therefore, a road with low cycle volumes should be just as safe as a road with high cycle volumes.

Explanation of Figure 3.4

- Area 1

If the V85 (85 percentile-speed) of motorised traffic is lower than 30 km/hour, mixed use of the road can be recommended. Segregated cycle tracks or on-road cycle tracks can still be constructed for subjective safety, and for the continuity of the cycling-network.

- Area 2

This area shows a combination of very low speeds with very high volumes. In this situation, speed is usually not a problem. However, the available space shared by cyclists and motorised traffic can be a problem. Segregation should be used to avoid chaotic situations.

- Area 3

In this area, mixed use of the road or on-road cycle tracks is acceptable. However, depending on other road and traffic features the provision of specific cycle facilities might still be preferable.

- Area 4

A segregated or on-road cycle track is desirable.

- Area 5

A segregated cycle track is preferable, but motorised traffic volumes are so low that mixed use of the road is also acceptable. On-road cycle tracks are not recommended (under these circumstances on-road cycle tracks might cause a false sense of security).

- Area 6

With high speeds and high volumes of motorised traffic, segregated cycle tracks are always necessary.

Other reasons for segregation include the need for continuity in the cycle network (uniformity).

FIGURE 3.4 | TYPE OF SEGREGATION BETWEEN CYCLISTS AND MOTORISED TRAFFIC WITH DIFFERENT COMBINATIONS OF SPEED AND VOLUME. VOLUMES FOR MOTORISED TRAFFIC ARE COUNTED IN BOTH DIRECTIONS (ON ONE CARRIAGEWAY)

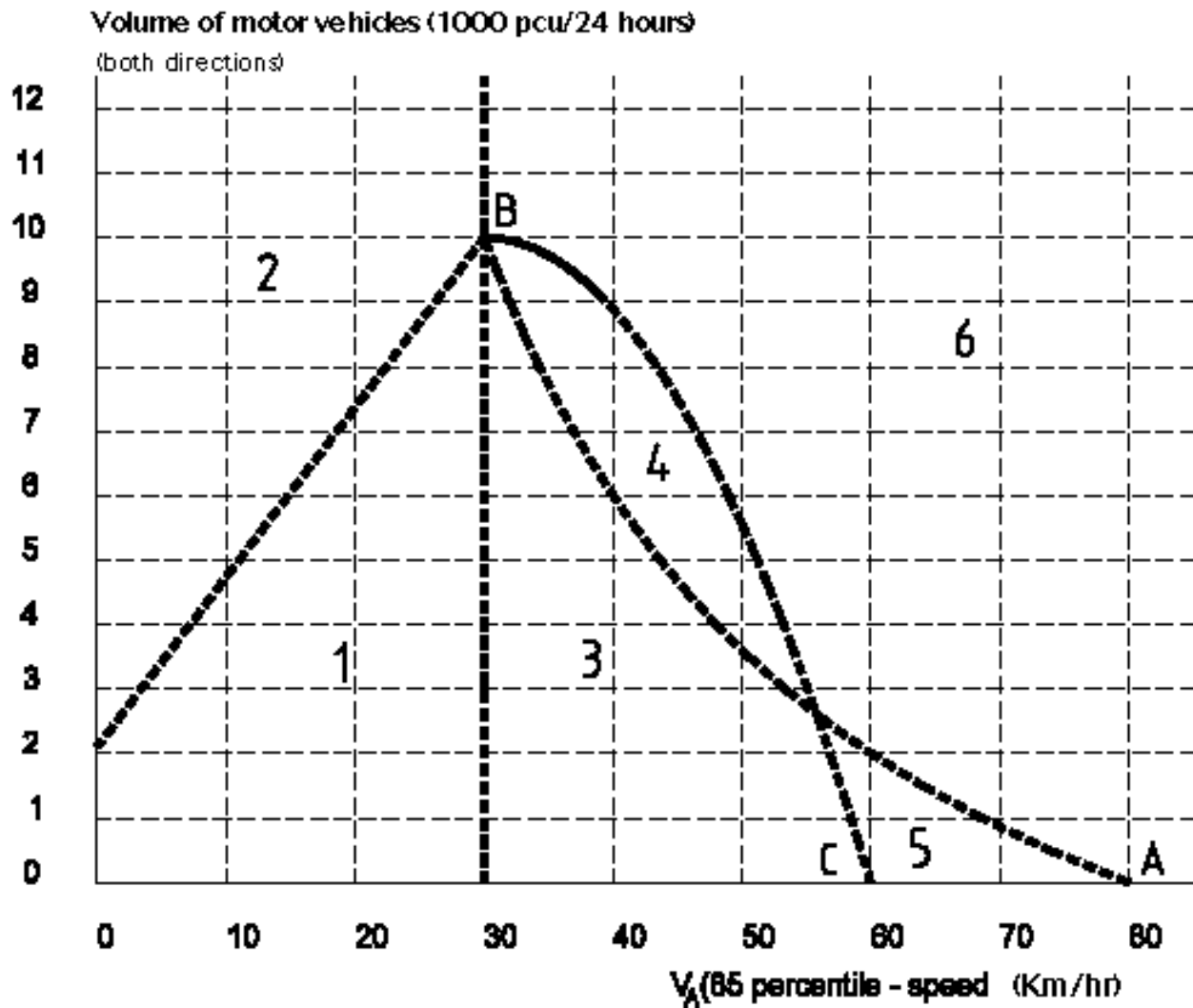

Explanation of figure

The horizontal axis of the graph gives the actual speeds of motorised traffic and not the legally permitted speeds or the design speeds. The vertical axis gives the volume of all motorised traffic on the carriageway.

3.3 Possible cycle facilities along road sections

After determining whether or not segregation is needed, the types of cycle facilities set out in the following table can be used.

TABLE 3.1 | TYPE OF SEGREGATION

Type of Segregation	Type of cycle facility	Reference to §
Physical segregation	two-way cycle track on one side	§ 3.4.2
	one-way cycle track on one side	§ 3.5
	one-way cycle track on both sides	§ 3.5
	contra-flow cycle track	§ 3.6
	two-way cycle track on both sides	§ 3.10 (indirectly)
	cycleway	§ 3.10
Visual segregation	on-road cycle tracks with a continuous line	§ 3.7
	on-road cycle tracks with a broken line	§ 3.7
	contra-flow on-road cycle tracks	§ 3.8
Mixed use of the carriageway	two-way traffic	§ 3.9.2
	one-way traffic	§ 3.9.2
	partial one-way traffic	§ 3.9.2
	one-way street except for cyclists	§ 3.9.2
Facilities for pedestrians and cyclists only	shopping and residential areas	§ 3.10
	canals	§ 3.10.1
	LRT	§ 3.10.2



Adjacent Cycle Track (Ireland)

3.4 Physical segregation

3.4.1 Space requirements for cyclists using a cycle track

Figure 3.5 shows the minimum amount of space needed by cyclists. Important design elements which should be considered are (all measured from the bicycle tyre):

- distance to the kerb or grass verge;
- height of the kerb;
- distance to fixed objects beside the cycle track;
- distance to walls or building frontages.

These minimum sizes are based on the following safety requirements:

- cyclists must be protected from the worst effects of steering errors;
- there must be safe margins for passing and overtaking movements, and meeting traffic in the case of two-way roads.

The total width of a cycle track depends on the volume of cycle traffic, and whether it is a two or a one-way cycle track. The required width of a cycle track in relation to different levels of usage and road types is given in table 3.2 below.

Pinch Points

If there is not enough space for a cycle track of the desired width, the road authority has to make a choice. The choice cannot be limited to the provision of a cycle track which is too narrow or mixed use of the road. When a route fulfils an important function for bicycle traffic, an attempt must be made, in spite of the lack of space, to guarantee the safety and comfort of cyclists. It is not expected that cyclists alone should make concessions in such a situation. Adjustments can be made to the traffic situation in order to limit motorised traffic.

In the process of creating a well balanced design at pinch points, planners, designers and road authorities are all equal partners in finding safe and creative solutions. (see § 3.7.4, fig. 3.16)

TABLE 3.2 | PREFERRED WIDTHS (AS SHOWN IN FIGURE 3.5) FOR A ONE-WAY CYCLE TRACK AND A TWO-WAY CYCLE TRACK WITH DIFFERENT VOLUMES OF CYCLE TRAFFIC

One-way cycle track		Two-way cycle track	
Peak-hour volume in one direction	width of cycle-track (m)	peak-hour volume in two directions	width of cycle-track (m)
0 - 150	1.75*	0 - 50	1.75*
150 - 750	2.50	50 - 150	2.50
> 750	3.50	> 150	3.50

* The minimum width of a cycle track is 1.50m. If this width is used the track should have soft kerb (preferably a compacted grass verge or a low kerb <0.05m on the left-hand side) which can be used by cyclists to take evasive action when passing or overtaking.

FIGURE 3.5 | PREFERABLE WIDTHS FOR ONE-WAY CYCLE TRACKS AND TWO-WAY CYCLE TRACKS

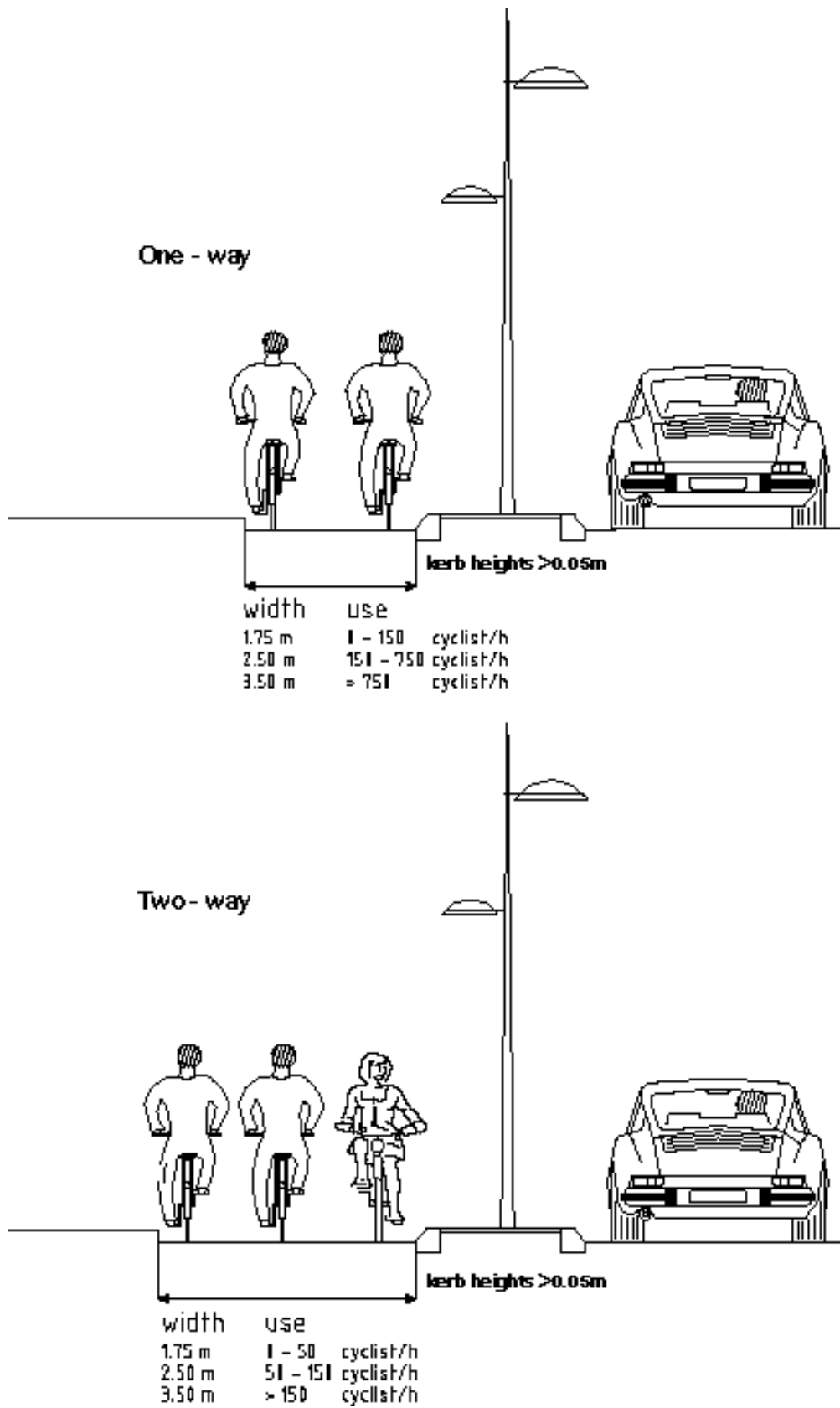

3.4.2 Two-way or one-way cycle tracks?

What can be applied

Where cycle routes are required in two directions, the choice will often be between:

- a one-way cycle track on either side of the road;
- a two-way cycle track on one side;
- a cycle track on both sides of a road, with two-way cycle traffic on one, or sometimes both tracks. This is recommended for busy dual carriageways because of the central road barrier.

A cycle track with two-way traffic has the following advantages and disadvantages, compared to two separate one-way cycle tracks. Both designs are shown schematically in figure 3.6:

Advantages:

- cyclists with origin and destination points on the same side of a road, need not cross the road. This can be very useful especially near schools.
- if a road has many side roads, a cycle track with two-way cycle traffic on the side with the least number of side roads, is safer for through cycle traffic than a one-way cycle track on each side of the road.
- where few side roads cross the cycle route, it is more comfortable to cycle on a 3.00m wide track with two-way traffic than on a narrower one-way track. It also means that less space will be taken because there is only one dividing verge between the cycle track and carriageway.

Disadvantages:

- problems arise at intersections. Motorists who have to give way to cyclists on a two-way cycle track, often expect cyclists to come from only one direction. This problem occurs much more outside built-up areas, and the danger can be reduced by good intersection lay-out (see chapter four);
- if a two-way cycle track on one side of a road is not well-connected to other routes, this can result in additional carriageway crossings, and increase the possibility of accidents.

To make the right decision, detailed information about the local situation is crucial.

Specifications

- A verge, 2.00m wide is preferable on a two-way cycle track. This will provide sufficient space for cyclists to wait at crossing locations.

General comments

- Along busy dual carriageways with few crossing points, cycle traffic on each side of the road can either use a two-way cycle track or make use of parallel roads.

FIGURE 3.6 | ONE WAY CYCLE TRACKS AND A TWO WAY CYCLE TRACK (OFF ROAD)

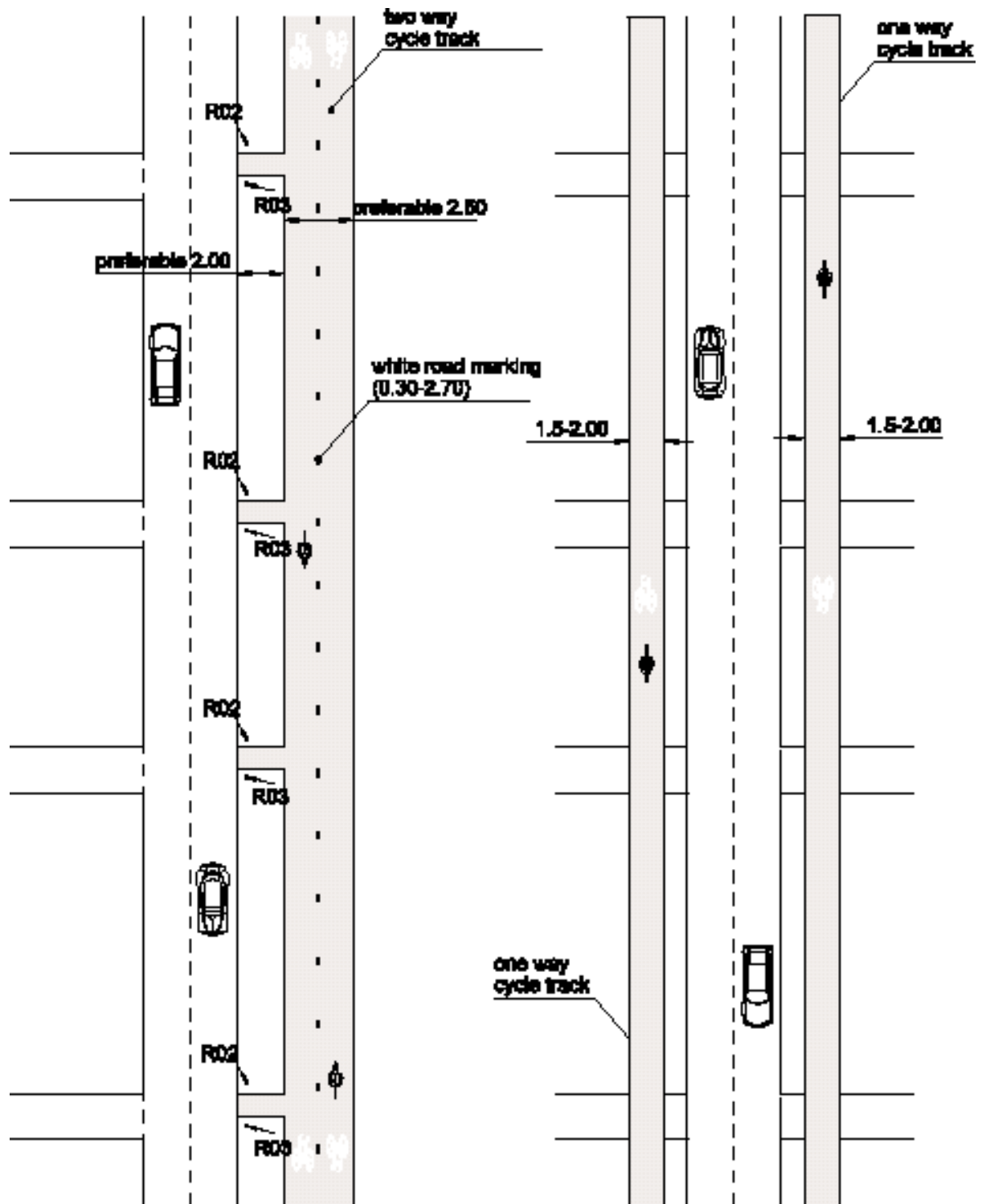

not to scale

3.5 Different means of physical segregation

TABLE 3.3 | WHERE TO APPLY THE DIFFERENT MEANS OF SEGREGATION?

Means of segregation	Where to apply?	Remarks
Grass verge	When the cycle track is built on the road verge.	Trees and bushes can be part of this segregation. Street furniture can also be placed in the dividing verge
Parking lane	At locations where high levels of parking manoeuvres pose potential injury risks to cyclists.	
Paving set at a higher level	In the situation where the carriageway will be narrowed.	The strip can also be used for street furniture like lighting and advertisements. It also can be combined with landscaping or be integrated with a design for bus lay-bys and parking facilities.
Raised edge	When physical protection is strongly needed but where space is limited.	Only to be used when the driving speeds of the motorised traffic on the carriageway do not exceed 50 km/h
Railing, wall or guard rail	At short road sections with very limited space, such as bridges or tunnels.	
Raised adjacent cycle track	When a cycle track is combined with a new or existing pedestrian footway.	A raised adjacent cycle track as a two-way cycle track provision should be avoided.

3.5.1 Grass verge (fig 3.7)

Specification

- If a grass verge is used, attention must be paid to the type of planting and maintenance. There should be a minimum obstacle-free space of 0.50m beside the cycle track.
- A kerb is needed to protect the edges of the cycle track and to keep the construction in good shape.

Dimensions

- Minimum width of the cycle track is 1.50m.
- Preferably the width of the verge should be more than 1.50m, but a minimum width of 0.50m is needed to allow for maintenance work.

FIGURE 3.7 | CYCLE TRACK WITH A GRASS VERGE

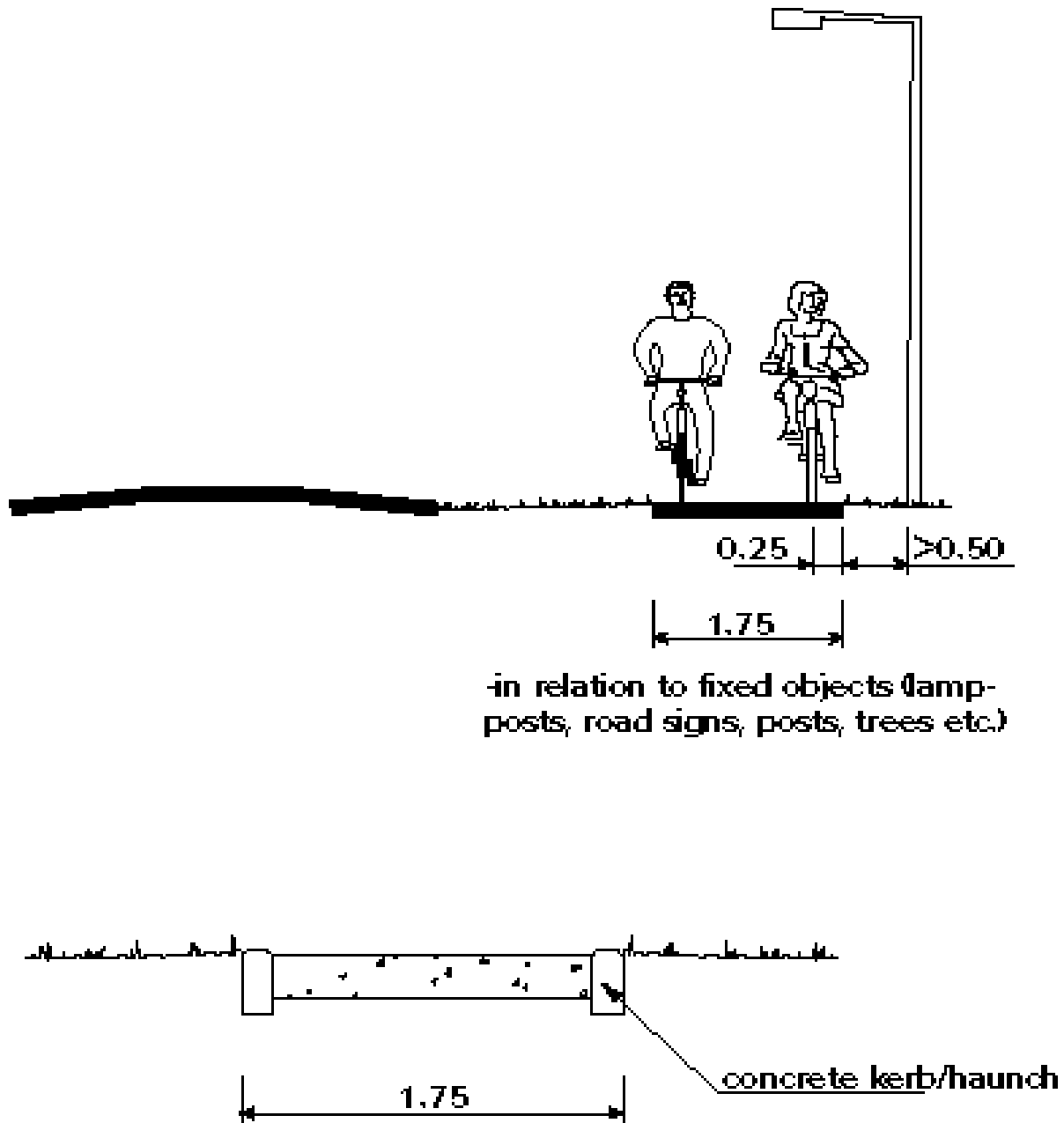

3.5.2 Parking lanes (fig 3.8)

Specification

- If parking is allowed between the traffic on the carriageway and cycle track, there should be a dividing verge with a minimum width of 0.80m to protect cyclists from the danger of opening car doors.

Dimensions

- Minimum width of the cycle track is 1.50m.
- The minimum width of a dividing verge between parking lanes and cycle tracks should be 0.80m, although 1.00m is preferable.

General comments

- Where there is high parking demand, extra physical protection (e.g. bollards) must be considered to avoid illegal parking on the cycle track.
- A dividing verge is particularly important at road sections where there is a high demand for short-term parking.

FIGURE 3.8 | DIVIDING VERGE BETWEEN A PARKING LANE AND A CYCLE TRACK

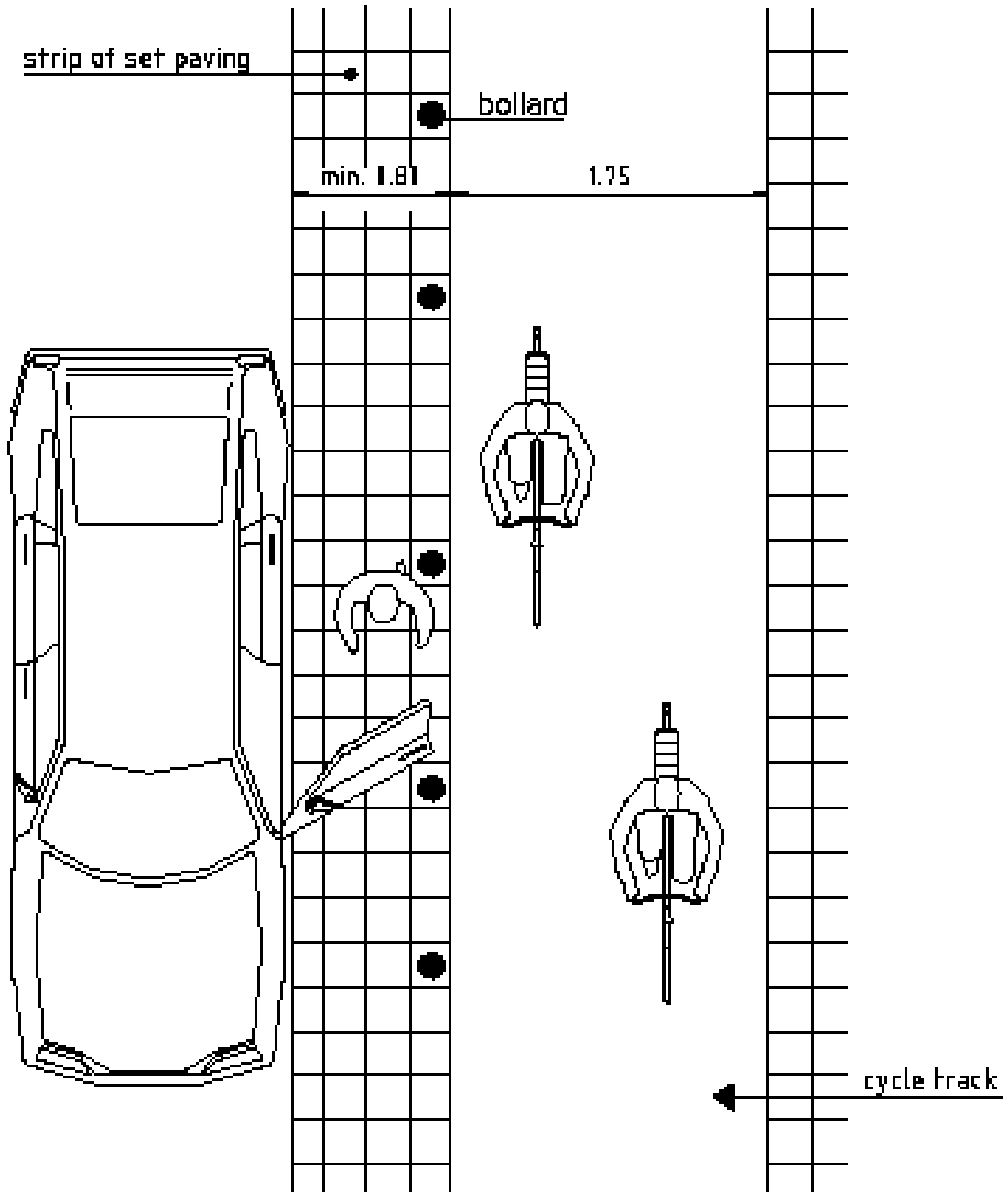

3.5.3 Paving sets (fig 3.9)

Specification

- Paving sets can function as a dividing verge.
- The strip of paving sets built at a higher level than the carriageway can be constructed out of concrete or granite kerbs in combination with concrete paviors or asphalt.

Dimensions

- The dividing verge should be 1.50m wide.
- If the width is less than 1.50m, special attention must be paid to the placing of street furniture. This has to be considered in relation to the fear of cyclists and motorised traffic of obstacles.

General comments

- The dividing verge can be used for street furniture, for example street bins and lamp posts.
- The dividing verge can also be integrated with the waiting area at bus stops and bus lay-bys. Some examples are shown in § 5.3.

FIGURE 3.9 | STRIP OF PAVING

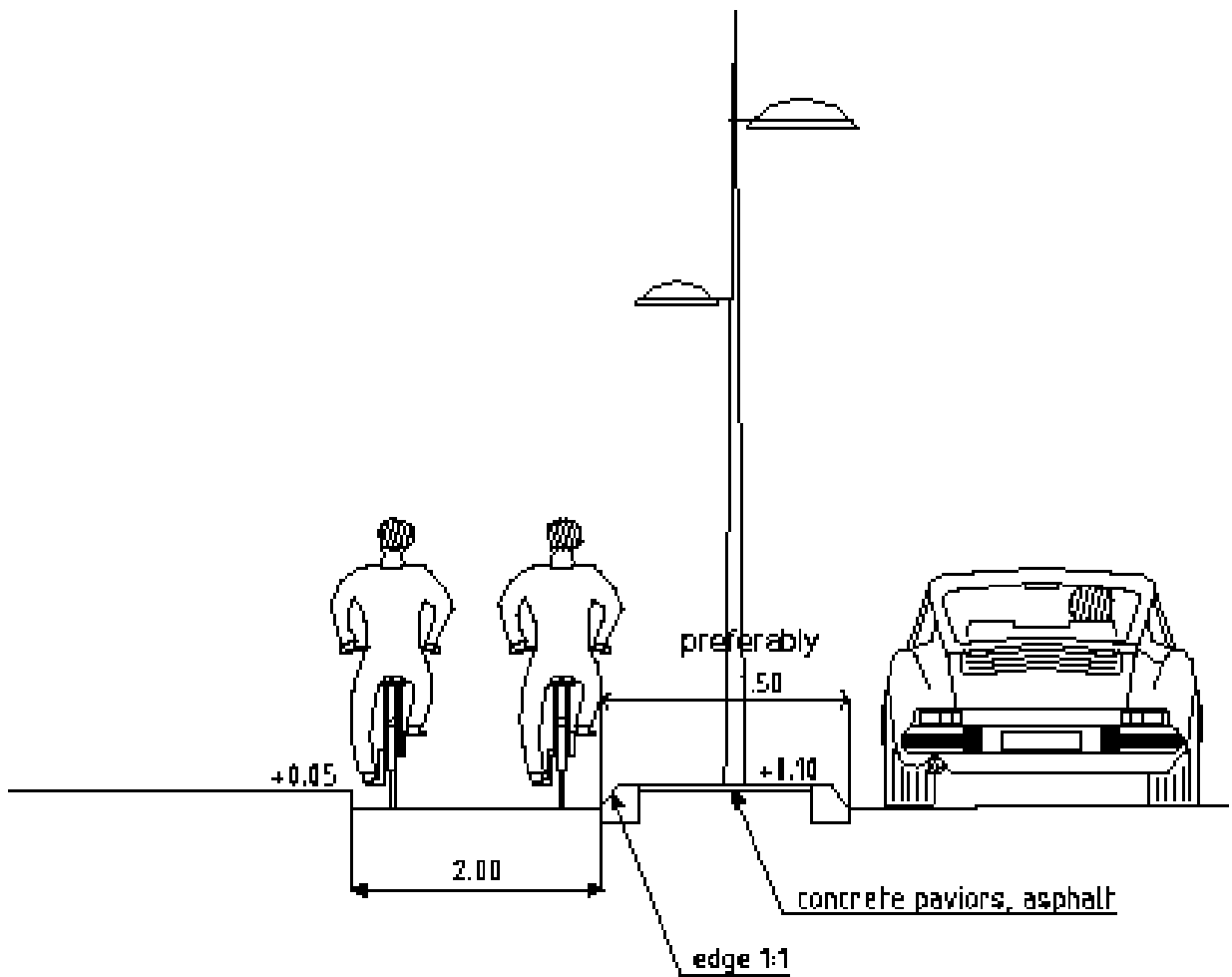

3.5.4 A raised edge (fig 3.10)

Specification

- A raised edge can only be used when the speed of motorised traffic on the carriageway does not exceed 50 km/h.
- A raised edge of concrete or asphalt is an example of a dividing verge, used if little space is available. A width of 0.50m is enough for this type of verge.
- At the side of a cycle track, the kerb should rise obliquely so that a cyclist, riding exactly parallel to the verge will not hit the raised edge with a pedal.

Dimensions

- Minimum width of the cycle track is 1.50m.
- The width of the dividing verge is approx. 0.50m, depending on the materials used.

General comments

- Extra attention must be paid to the visibility of the edge, particularly in the dark.
- Street lighting should be positioned left of the cycle track.
- No signs, marker posts etc. should be positioned on the edge.
- Drainage and litter accumulation can also cause problems. These can usually be prevented by introducing gaps of approximately 0.10m in the raised edge.

- Concrete kerbs are usually used to construct the raised edge. Plastic elements are also available; however they give less protection and should be used only in situations with low traffic volumes (preferably below 6000 p.c.u and speeds below 50 km/h). Plastic elements are effective in segregating cycle traffic from pedestrians.
- The costs of using a raised edge as segregation are relatively low.

FIGURE 3.10 | TWO DESIGNS FOR A RAISED EDGE

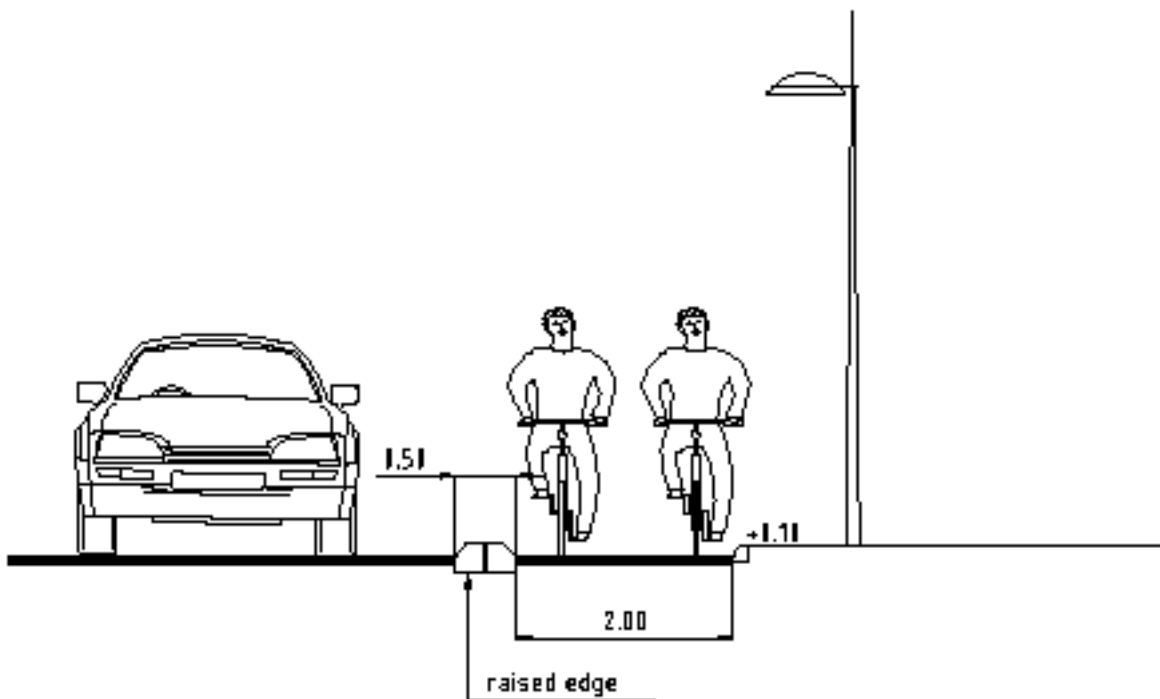
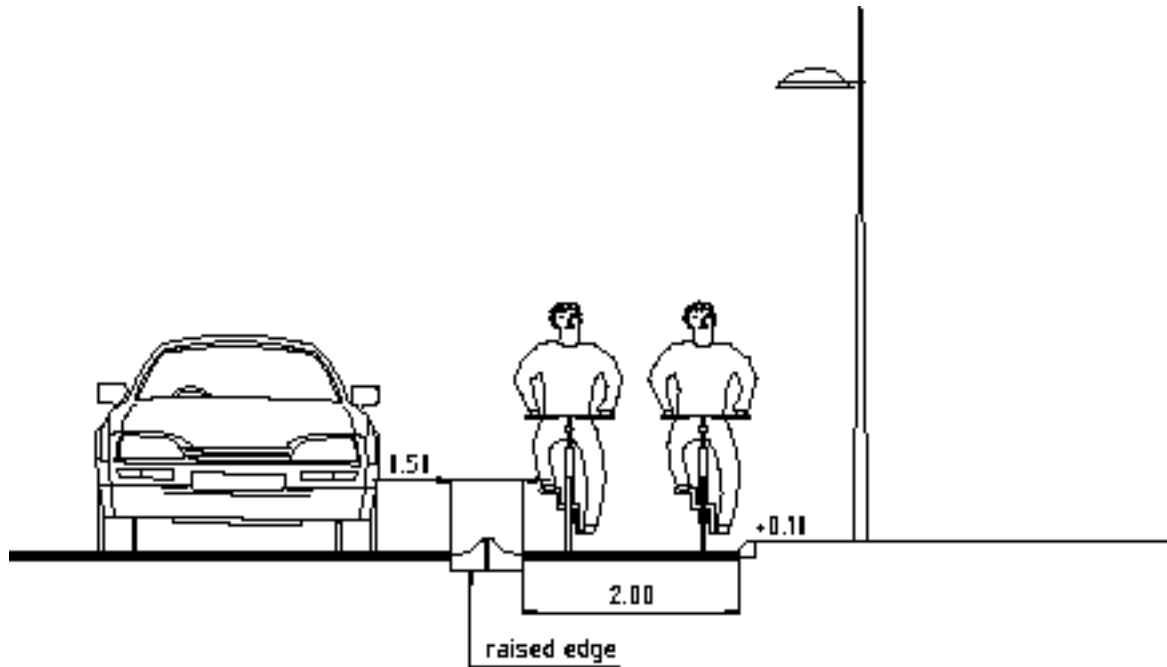

3.5.5 Railings, safety fencing or walls (fig 3.11)

Specification

- Used for segregation at bridges or in tunnels.

Dimensions

- Because cycle traffic has no manoeuvring space when these means of segregation are used, the width of the cycle track should be greater than the minimum size (see table 3.2), unless it is used over a short distance (less than 20m), such as a bridge.
- A width of 2.00m is recommended.

General comments

- Where gusting wind is a problem on high bridges, and where there is no space for a wide separating shoulder, a railing or a wall will prevent cyclists being forced off the cycle track.
- A wall can offer good protection against adverse weather conditions, but at the same time reduces the perception of safety, and the attractiveness of the track.
- On roads with extremely high traffic speeds, a crash barrier offers cyclists good protection.
- On large bridges a two-way cycle track should be provided on each side. This should be designed as part of the whole cycle network.

FIGURE 3.11 | SEGREGATION BY MEANS OF A RAILING, SAFETY FENCE OR WALL

RAILING

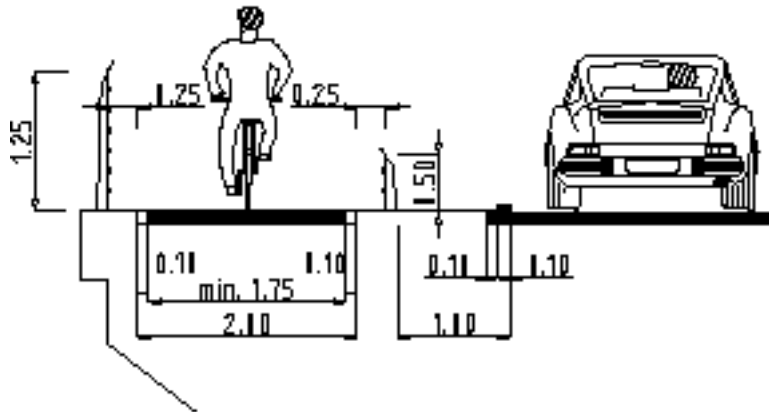

SAFETY FENCE

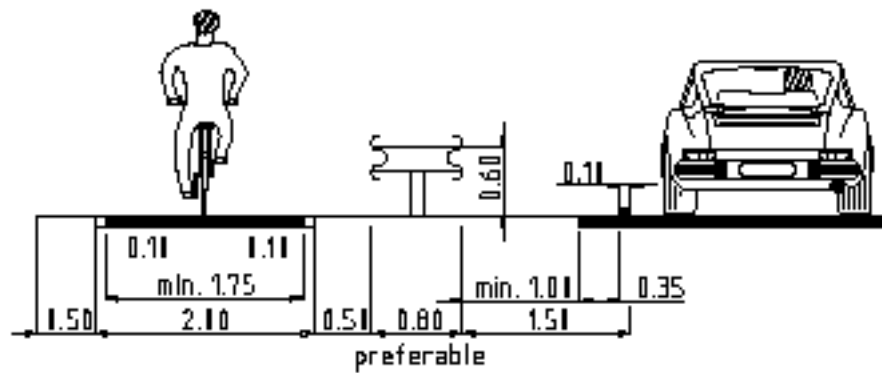

WALL

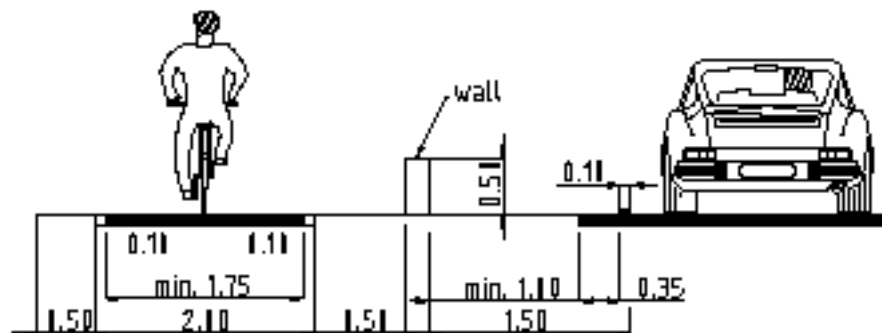

3.5.6 Cycle track on the footway

A cycle track on a footway can be provided as a:

- one way cycle track;
- two way cycle track.

Specification

One way adjacent cycle track: *(figure 3.12)*

- The cycle track is adjacent to the carriageway. There is no room for pedestrians between the cycle track and the carriageway except for crossing the road.
- Street furniture cannot be placed between the cycle track and the carriageway.
- Cycle traffic travels in the same driving direction as the traffic on the adjacent carriageway.
- Segregation between cyclists and the pedestrians may be indicated with a continuous white line or preferably by a small raised kerb of 0.05m.

Two way cycle track:

- Street furniture can be placed between the two way cycle track and the carriageway.
- Segregation between pedestrians and the cyclists can be achieved with a slightly raised kerb of 0.05m. Line markings should only be the last option since high volumes of cyclists are to be expected.

- A two way cycle track on the footway should not be provided directly adjacent to the carriageway. This will lead to oncoming cyclists being blinded at night-time due to the track's proximity to the carriageway. Secondly for oncoming cyclists there is no room for deviation at the side of the carriageway. On safety grounds this design should be avoided.

One way cycle track and a two way cycle track:

- Proper street lighting should be provided.

Dimensions

One way adjacent cycle track:

- The width of the dividing verge is zero. Segregation is created by a kerbstone which gives a height difference of at least 0.10m.
- Cyclists should keep a safe distance from the edge of the cycle track and the carriageway. A white line at a distance of 0.10m minimum from the kerb will help to achieve this.
- The width of the track should be made a little wider than is suggested in table 3.2, column "one-way traffic": a minimum of 0.25m should be added.

Two way cycle track:

- The width of the cycle track based on the cycle volumes is preferably between 1.75 and 3.50m.
- The width of the footway between the cycle track and the carriageway should be a minimum of 1.8m. However the preferable width should be based on pedestrian numbers.

FIGURE 3.12 | RAISED ADJACENT CYCLE TRACK

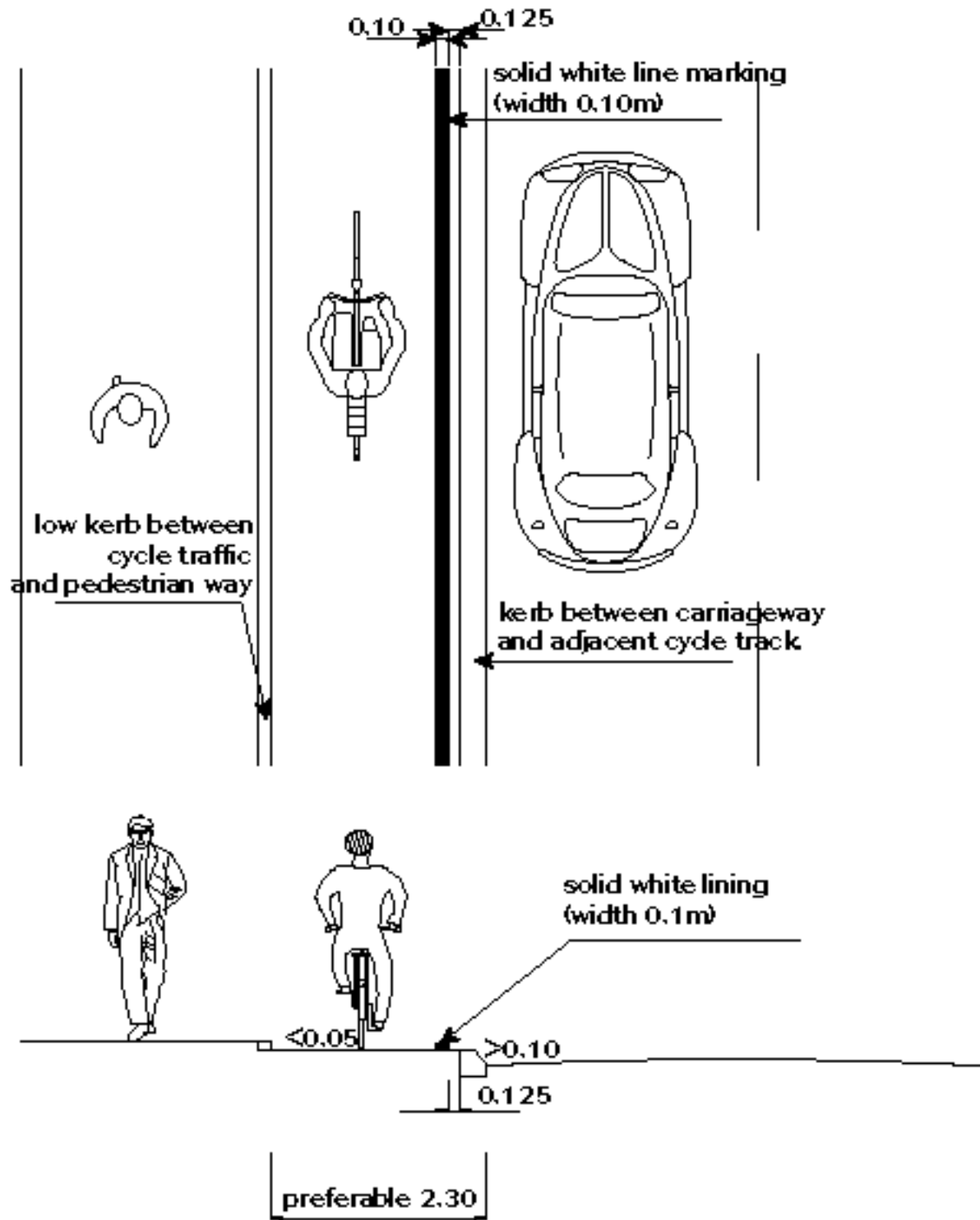

3.6 Contra-flow cycle tracks

Where to apply

If the volume of motorised traffic exceeds 2000 vehicles/day, physical segregation for contra-flow cycle traffic is recommended.

Specification

- The same specifications as for different forms of segregation can be applied to contra-flow cycle tracks (see § 3.5 and fig 3.13).

Dimensions

- The width of the cycle track should be a minimum of 1.50m.

General comments

- To prevent cyclists having to make detours it is desirable to provide for two-way cycle traffic on all roads, particularly on all new traffic calming schemes.
- Use figure 3.4 to decide whether segregation is necessary for the cycle traffic moving in the same direction as motorised traffic.

FIGURE 3.13 | SEGREGATED CONTRA-FLOW CYCLE TRACK

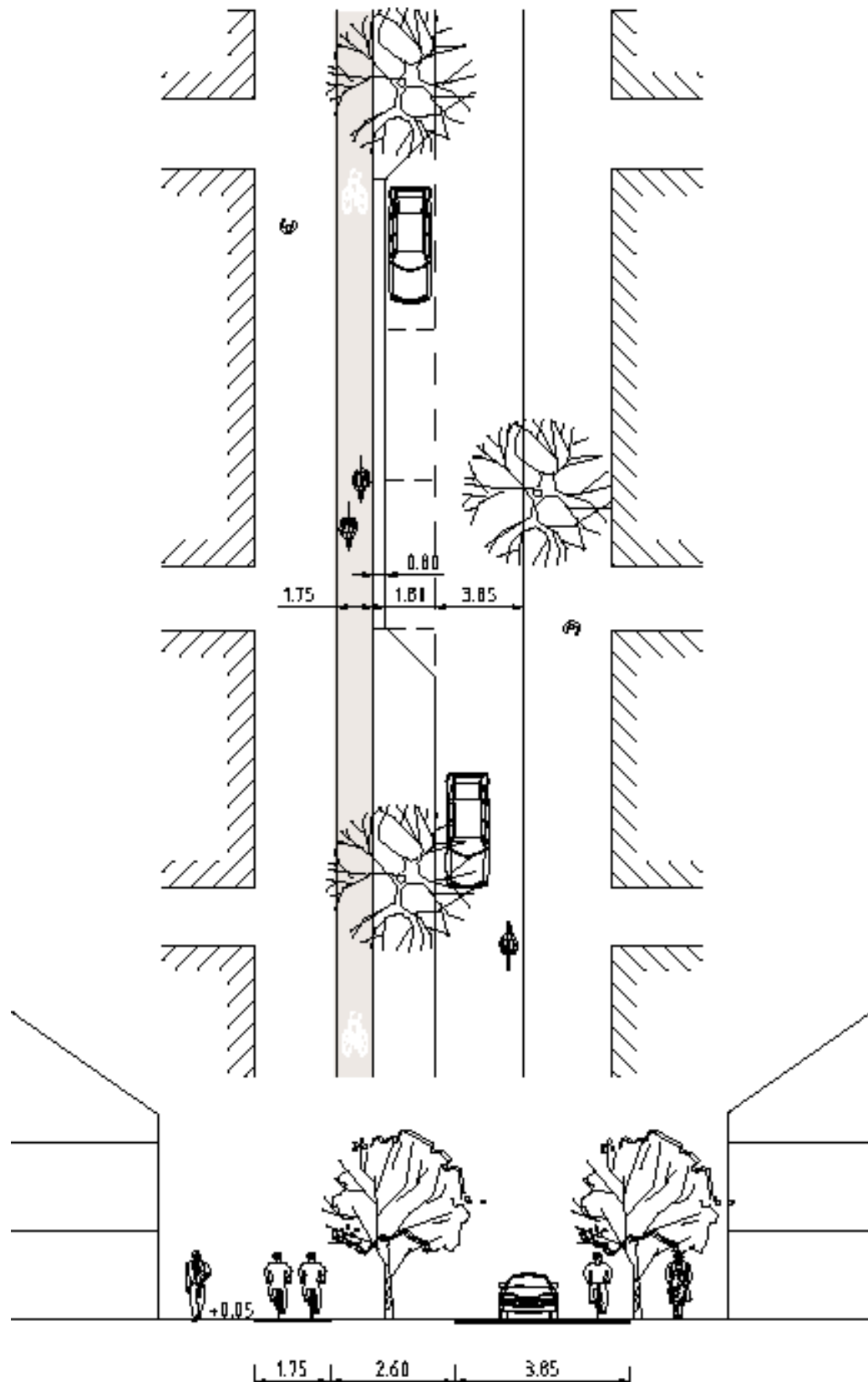

3.7 On-road cycle tracks

3.7.1 General

Specification

- The on-road cycle track is part of the carriageway.

Dimensions

- The absolute minimum width of an on-road cycle track is 1.25m (excluding road markings).
- The preferred width of an on-road cycle track is between 1.50m and 2.00m. This is determined by the following:
 - two cyclists should be able to ride side-by-side without any difficulty.
 - cyclists must be able to keep a safe distance from parked cars without deviating from the track. This also applies when two cyclists ride side-by-side.

Legal status

- Cycle traffic on an on-road cycle track has equal priority to other traffic using the carriageway.

General comments

- When the volume of cycle traffic is high, a width of 2.00m is recommended.

3.7.2 On-road cycle track and parking

- Cyclists must be able to keep a safe distance from parked cars without deviating from the on-road cycle track. To give cyclists some protection from opening car doors, a deterrent strip of 0.80m wide between the parking lane and the on-road cycle track should be provided.
- If angular parking is allowed, the deterrent strip should be between 1.00m to 1.50m. The deterrent strip will improve the sight-lines for car drivers leaving the parking area.
- In shopping streets where regular loading and unloading takes place, special loading/unloading bays should be constructed. If this is not done, goods traffic will use the deterrent strip, the on-road cycle track and the parking spaces. An example of this special loading/unloading bay is shown in figure 3.14.

FIGURE 3.14 | NECESSARY SPACE FOR AN ON-ROAD CYCLE TRACK, DETERRENT STRIP, PARALLEL LOADING/
UNLOADING BAY

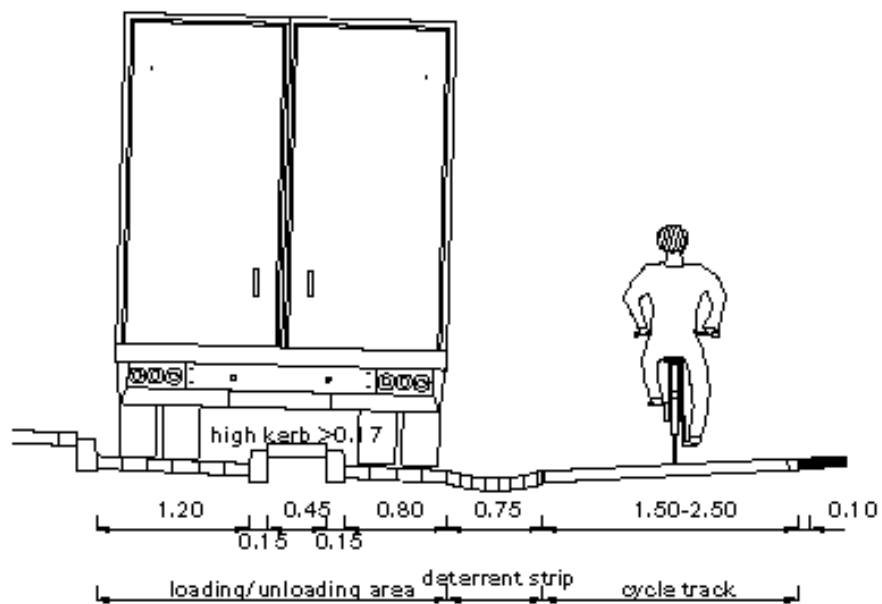
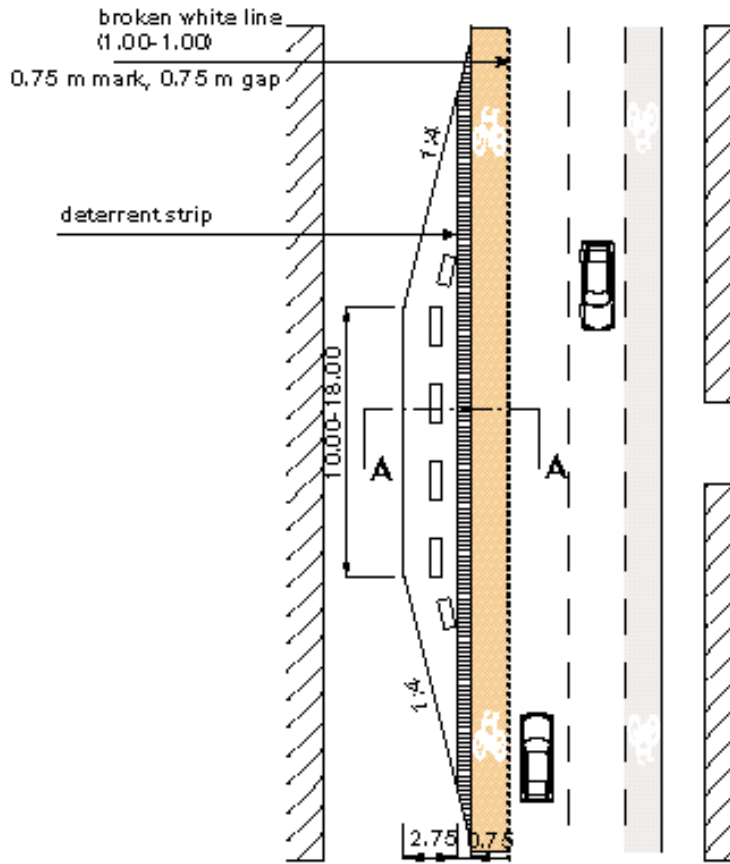

section A-A

3.7.3 On-road cycle tracks with a continuous or a broken line (Table 3.4 and fig 7.3)

The following recommendations are made for on-road cycle tracks with either a continuous line or a broken line.

Specification

- It is preferable that on-road cycle tracks have a red surface in order to give them greater emphasis. The use of the red surfacing will also improve the road safety of the cycle facility.
- An on-road cycle track is identified at the start of the track with the sign R02. Along the route the cycle logo on the road surface should be used to emphasise the on-road cycle track.

- The logo should be repeated every 75m, and, before and after every junction and side road. For increased safety the logo can be placed at bus lay-bys and at petrol stations. It is unnecessary to repeat the logo at the access to private land.

Where to apply

An on-road cycle track with a broken white line is only used when there is a clear need for motorised traffic to cross the cycle track or for the cyclist to depart from the track e.g. at a narrow carriageway (Fig. 3.15).

TABLE 3.4 | RECOMMENDATIONS FOR THE APPLICATION OF ON-ROAD CYCLE TRACKS

Situation	Apply:
bus lanes	An on-road cycle track with a broken line
bus stops	An on-road cycle track with a broken line
bus lay-by	An on-road cycle track with a broken line
parking bays	An on-road cycle track with a broken line
carriageways	Preferably an on-road cycle track with a continuous line
junctions	An on-road cycle track with a broken line
contra-flow	An on-road cycle track with a continuous line



On Road Cycle Track (Holland)



Two-Way Cycle Track (Ireland)

3.7.4 On-road cycle track at pinch points

Definition of pinch points

Two types of pinch points can be distinguished:

- A road section may be classified as a pinch point because of the many functions that are taking place at that section. A solution can be found by analysing the functions of the road section and reallocating the available space between the different functions. For instance, by eliminating parking bays, more room can be made available for other road users (fig 3.16).
- A road section may be classified as a pinch point because of the very narrow roadway width. Here the functions are already optimised (fig 3.15).

Where to apply

- On distributor roads (or residential streets) with limited width (< 7.00m) on the carriageway. Volumes of motorised traffic should be less than 6,000 vehicles/day, and the 85th percentile speed of motorised traffic should be less than 30 km/h.
- Particularly applicable at shopping areas and road sections with a lot of emphasis on the activities alongside the carriageway.

Specification

- To emphasise the position of the cycle traffic, the on-road cycle track should be coloured red.
- The on-road cycle track must be marked with a broken white line.
- Cycle logos are to be used.
- No central line on the carriageway is used.

Dimensions

- The minimum width of the traffic lane is 3.50m.
- The preferable minimum width of an on-road cycle track is 1.50m as per Fig. 3.16. If the width of the carriageway is 6.00m then a minimum cycle track width of 1.25m can be used.

Legal status

- The on-road cycle track should have a broken white line.
- Motorised traffic is permitted to cross the on-road cycle track in order to pass traffic from the opposite direction as long as they do not hinder the cycle traffic.

General comment

- This design is clearly weighted in favour of cycle traffic. It is very effective at shopping areas and is in line with environmental traffic design.

FIGURE 3.15 | ON-ROAD CYCLE TRACKS AT A NARROW CARRIAGEWAY

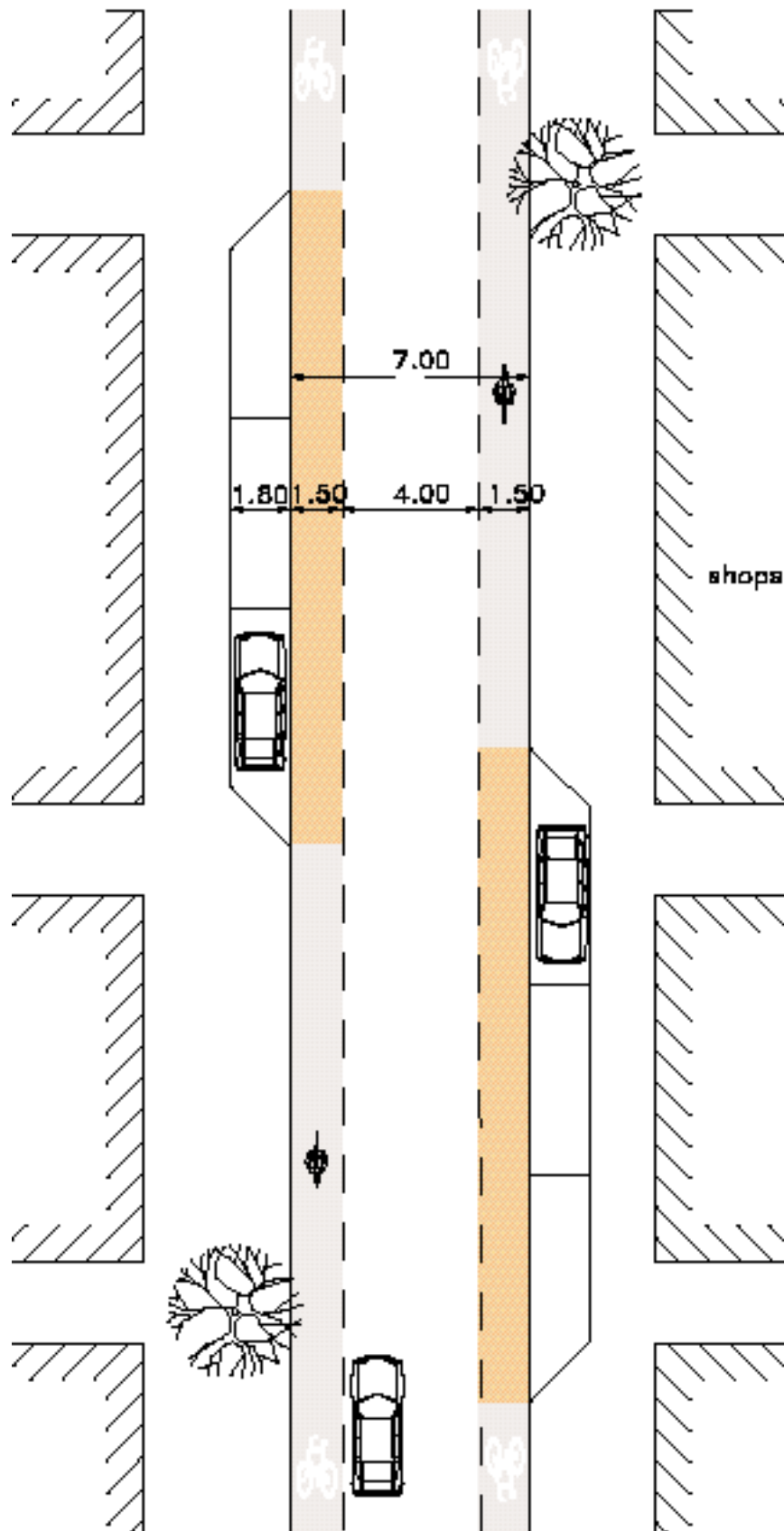
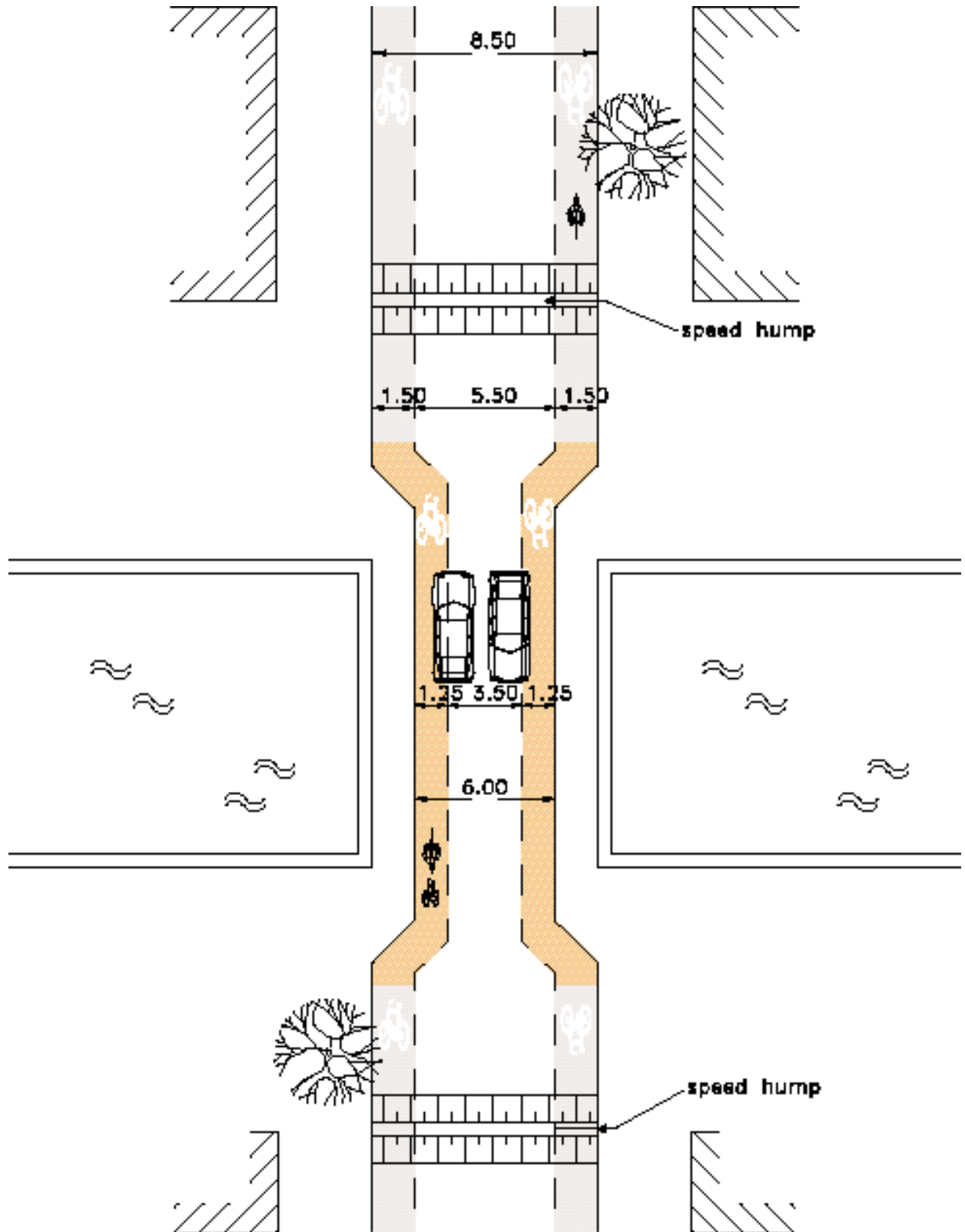

FIGURE 3.16 | ON-ROAD CYCLE TRACKS AT A PINCH POINT



3.8 Contra-flow on-road cycle tracks (fig 3.17)

Where to apply

If the volume of motorised traffic using one-way roads is between 1000 and 2000 vehicles/day, there should be an on-road cycle track for the contra-flow cycle traffic. When the traffic flows exceed 2000 vehicles/day a segregated contra-flow cycle track should be provided.

Specification

- To emphasise the position of the contra-flow cycle traffic, the on-road cycle track should be coloured red.
- The contra-flow on-road cycle track must be bordered with a continuous white line.
- Measures should be implemented to ensure that driving speeds of motorised traffic do not exceed 30 km/h.

Dimensions

- An on-road contra-flow cycle track must be bordered by a continuous white line.
- The width of the carriageway should be either 3.85m or 5.45m (see also § 3.9).
- The minimum width of a contra-flow on-road cycle track is 1.50m (and not 1.25m as normally used for with-flow cycle tracks).
- The preferred width is 1.75m.
- The maximum width of 2.00m should be used where there are high volumes of cycle traffic.

General comments

- Contra-flow cycle facilities should always be considered for one-way streets and for all new traffic calming schemes.
- Deciding whether visual or physical segregation is needed for cycle traffic moving in the same direction as the motorised traffic depends on the outcome of applying figure 3.4.
- At junctions, extra facilities (like bollards, flower baskets or kerbstones) might be needed to emphasise the contra-flow on-road cycle track. These facilities give cyclists greater protection at junctions, and will prevent misuse by other traffic.

FIGURE 3.17 | CONTRA-FLOW ON-ROAD CYCLE TRACK

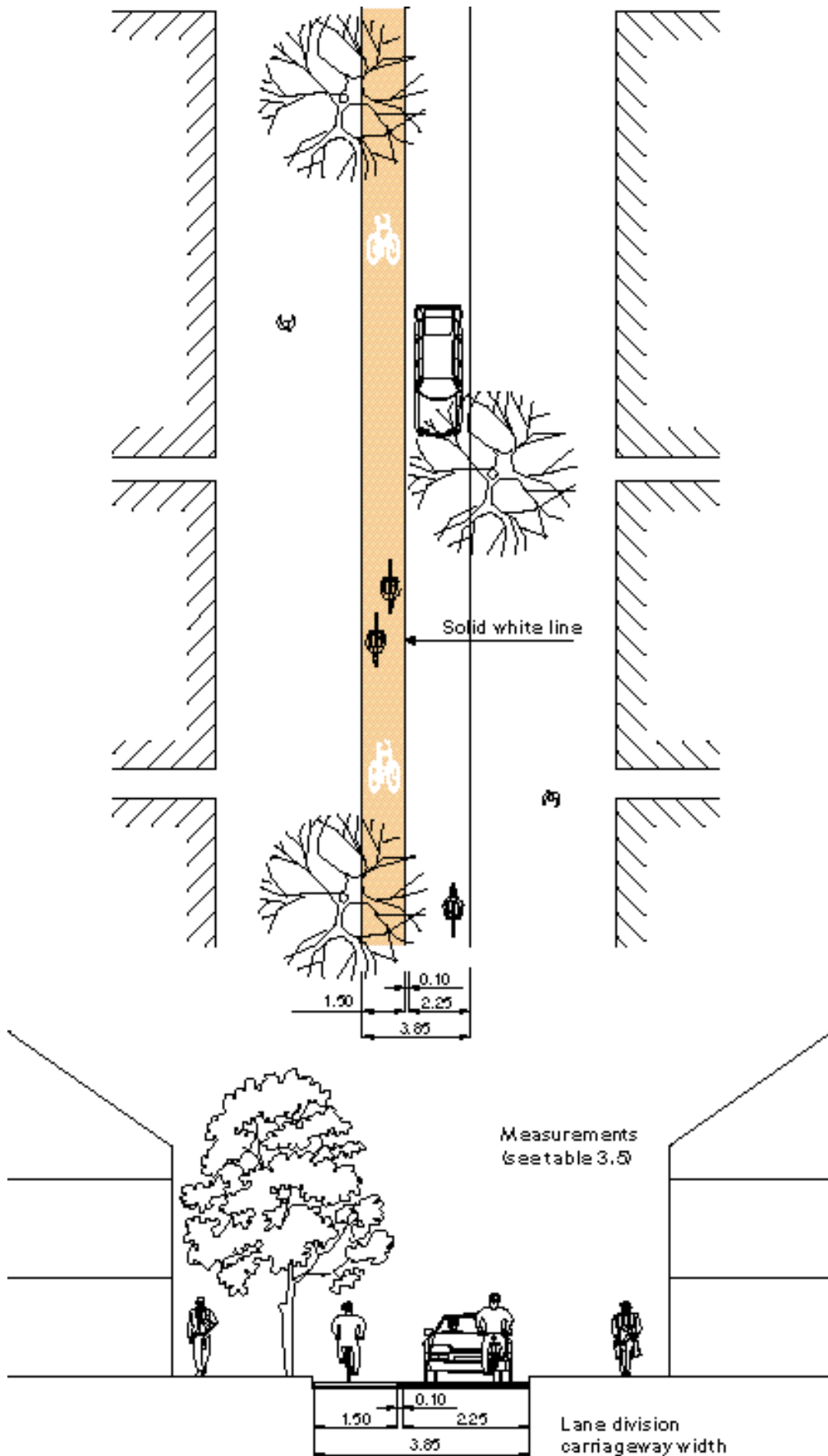

3.9 Carriageway width for mixed traffic use

Roads with mixed traffic can be divided into three types of cross-section:

Narrow cross-section

On roads with a narrow cross-section, there is little space for overtaking manoeuvres. If motorists wish to overtake a cyclist, they must wait until another traffic lane is free, or for a cyclist to make space for overtaking. A narrow cross-section leads to lower driving speeds, and the road design should make it clear that motorised traffic must adjust its driving behaviour to the requirements of bicycle traffic.

Wide cross-section

On a road with a wide cross-section, motorised traffic has always enough room to overtake cyclists. The disadvantage of a wide cross-section is the likelihood of high driving speeds.

A narrow or a wide cross-section can be applied on one-way and two-way streets.

Critical cross-section width

A critical cross-section road lies between a narrow and a wide cross-section, giving just enough space for close overtaking manoeuvres. It produces dangerous overtaking manoeuvres, and in contrast to a narrow cross-section can lead to higher motorised traffic speeds. A critical cross-section should be avoided, if at all possible.

3.9.1 Methodology

To find the appropriate carriageway width, based on a narrow or a wide cross-section, the following steps should be taken.

Please use table 3.5 and figure 3.18:

1. Determine the road function;
2. Estimate the typical intended use; the estimate of typical use is the most usual traffic combination on that particular road. This does not mean that the road is unsafe or cannot be used by other traffic combinations. For instance, if the typical use is bicycle-car-bicycle then the road width will also allow for a passing lorry. If there is a lot of car traffic and only a few cyclists, then a typical use could be car-car-bicycle. The required road width is calculated by totalling the combined widths of all vehicles which can pass or meet each other at one point using the estimate of typical use. In figure 3.18 the typical use is: goods vehicle-car-bicycle;
3. Calculate the carriageway width using the relevant measuring-segments in table 3.5 and based on the typical use;
4. Check the calculated carriageway width against the other possible combinations of road users (for example: to what extent does goods traffic fit onto the calculated carriageway width?).

If there is not enough space available for the calculated carriageway width, the function of the road should be considered again. This is an interactive process, involving both designer and decision-maker. It is only completed when a balance has been found between the function, the use and the design of a road.

The carriageway width as determined for mixed traffic use is the effective width for moving traffic. Road space needed for parking facilities is not included in this figure.

TABLE 3.5 | MEASURING DRIVING SPEEDS TO DETERMINE THE WIDTH OF A CROSS-SECTION (SIZES IN METRES)

Driving Speed Measuring-segment	Maximum 30 km/h	Maximum 50 km/h
Cyclist		0.75
Passenger car		1.75
Goods vehicle		2.60
Bicycle to edge (kerbstone)		0.25
Bicycle to parked vehicle		0.50
Bicycle to moving vehicle	0.85	1.05
Vehicle to vehicle (both moving)	0.30	0.80
Moving vehicle to kerb	0.25	0.50

The measurement bicycle-to-vehicle is greater than the measurement vehicle-to-vehicle. This is because the behaviour of bicycle traffic is more difficult to predict than that of motorised traffic. Bicycle traffic is also more vulnerable.

FIGURE 3.18 | MEASURING SEGMENTS

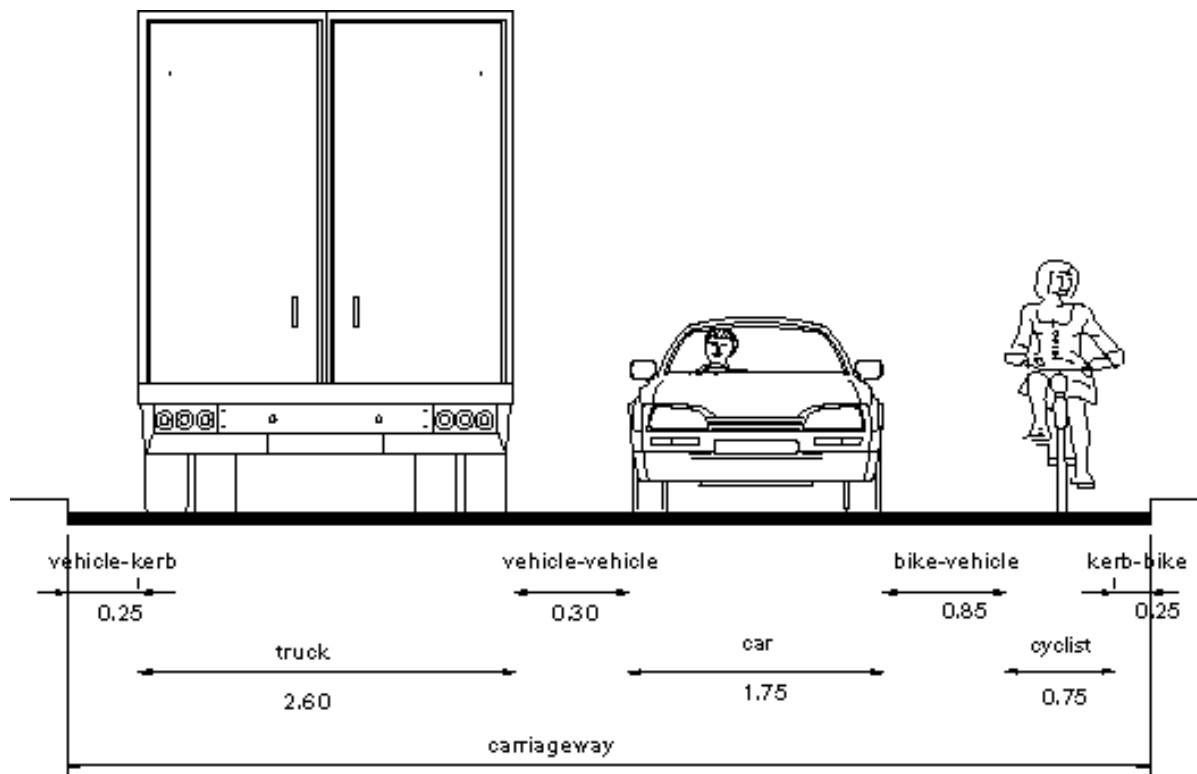

3.9.2 Some examples of a narrow or wide cross-section per road category

One-way traffic

A narrow cross-section on a one-way street could be designed as shown in figure 3.19.

There is simply no room for car or lorry traffic to overtake cyclists. This situation should only be applied over short distances (less than 300m) which is usually no problem in areas and streets with low traffic volumes.

One-way vehicular traffic and two-way cycle traffic

This situation can be compared with a street for one-way traffic and contra-flow cycle traffic, where contra-flow facilities are not implemented. However, contra-flow facilities can only be left out if the volume of motorised traffic is less than 1000 vehicles/day (classified as a residential street) and the 85th percentile speed is less than 30 km/h. The only facilities required are road signs at junctions to indicate that, unlike motorised traffic, cycle traffic is allowed in both directions. If the road links up with a busy main road, more physical facilities are required to underline the status of a one-way street with cycle contra-flow.

FIGURE 3.19 | ON A ROAD WITH ONE-WAY TRAFFIC AND A NARROW CROSS-SECTION WITH TRAFFIC SPEEDS NOT MORE THAN 30 KM/H AND A LANE WIDTH OF 2.60M, VEHICLES STAY BEHIND THE CYCLIST

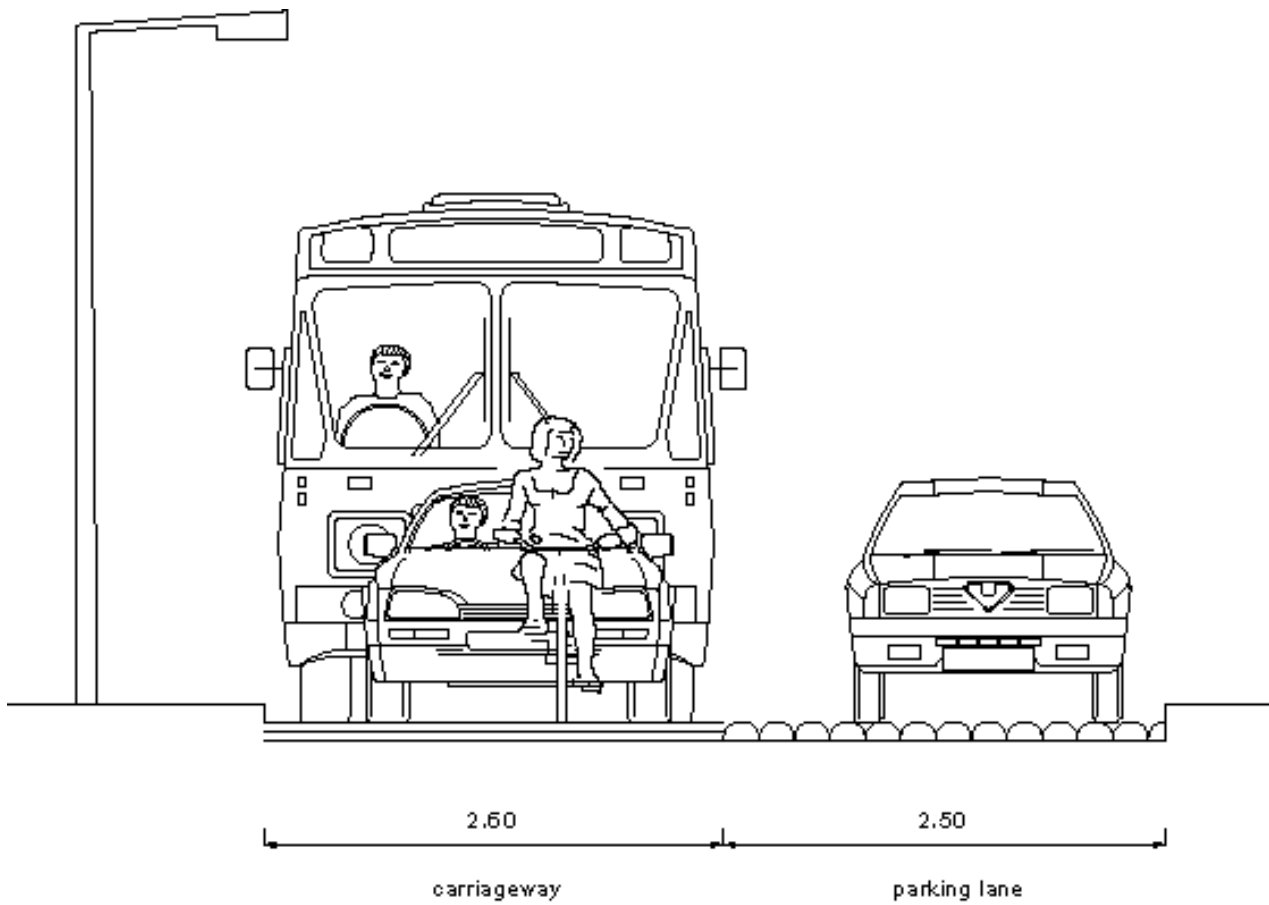

One-way traffic with a contra-flow cycle track

A one-way road with a contra-flow cycle track allows cycle traffic to make better use of the network. See top cross-section of figure 3.20. The contra-flow on-road cycle track should be constructed using red tarmac. If for some reason no contra-flow can be used, then a lane width of 3.85m will give a wide cross-section for one-way streets (typical use: bicycle-car).

The middle illustration shows a wide cross-section for one-way motor traffic. The lane width reflects the typical use of bicycle-car-bicycle. There will not, therefore, be sufficient space for a wide vehicle to pass two cyclists at the same time (see figure 3.20). This represents a narrow cross-section for bicycle-lorry-bicycle use. If the volume of H.G.V. traffic is high (> 60 H.G.V. /hour), then a wide cross-section of 6.30m should be used.

FIGURE 3.20 | THREE EXAMPLES OF A ROAD WITH ONE-WAY MOTOR VEHICLE TRAFFIC

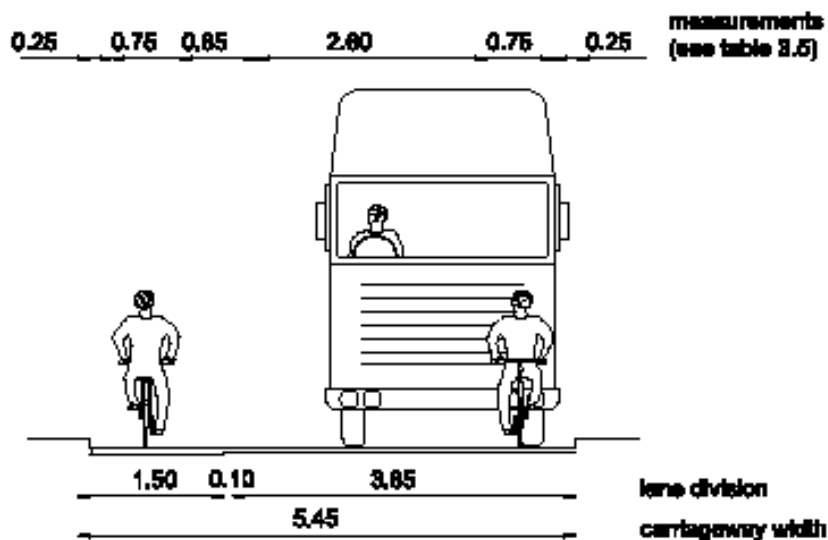
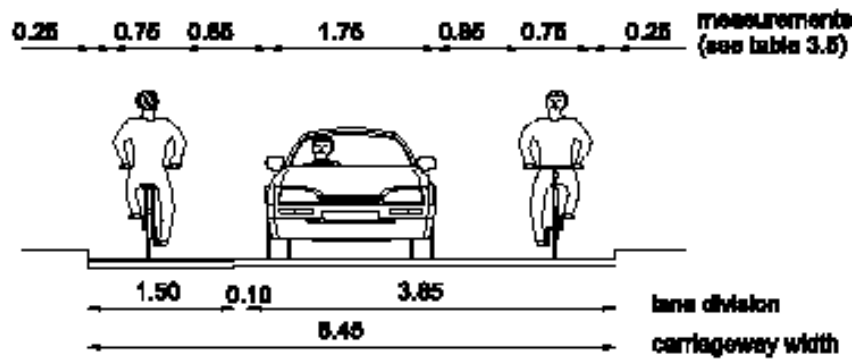
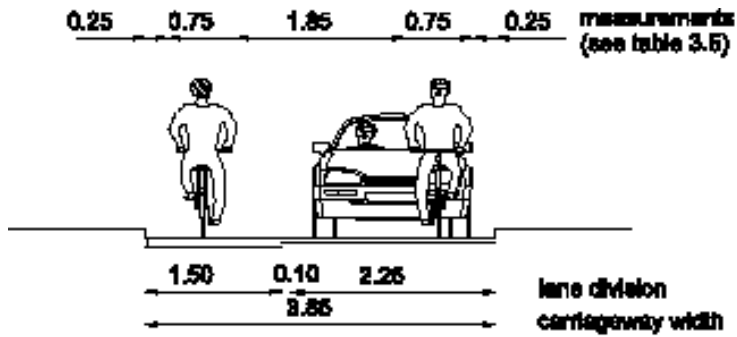



Cycle Facilities (Holland)

Two-way traffic

It is important that on roads with two-way traffic, various traffic combinations are carefully examined to determine the typical combination.

Two cars meeting one another (not goods traffic), is typical of a narrow cross-section. The carriageway width where the maximum speed is 30 km/h is then determined as follows:

$$0.25 + 1.75 + 0.30 + 1.75 + 0.25 = 4.30\text{m}$$

(see table 3.5).

As already mentioned, this carriageway width is narrow and should only be applied on short residential road sections, or when there is little goods traffic. This situation, as shown in figure 3.21, will rarely occur on roads with low traffic volumes. Here a carriageway width of 4.30m is acceptable.

A carriageway width of 5.45m is recommended on roads where there are high levels of bicycle traffic. This width is geared to the typical combination of bicycle-car-bicycle as shown in figure 3.18.

Figure 3.22 is another example of a wide cross-section with a typical use of car-car-bicycle.

FIGURE 3.21 | ROAD WITH TWO-WAY TRAFFIC AND A NARROW CROSS-SECTION. MAXIMUM SPEED IS 30 KM/H

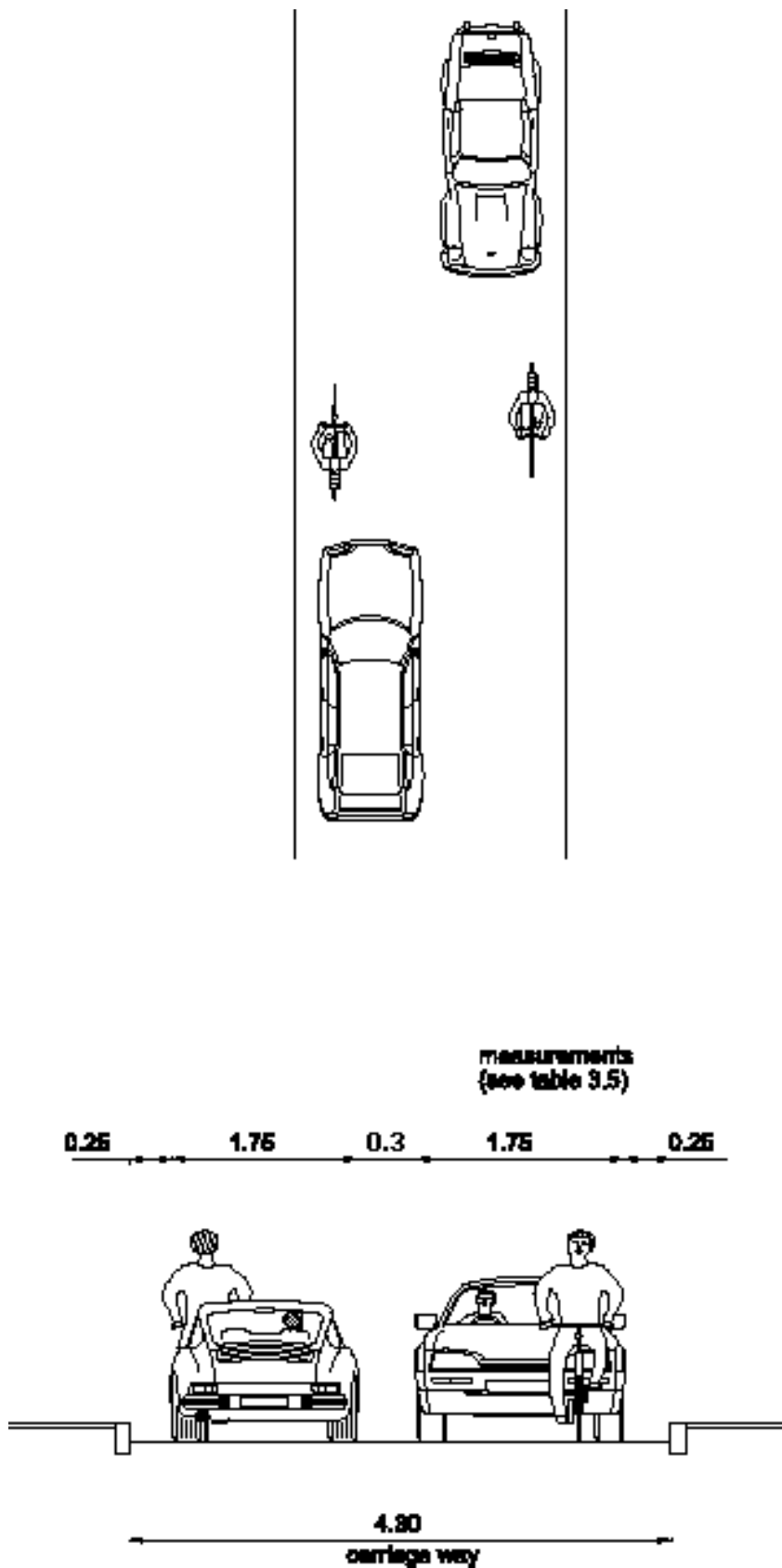
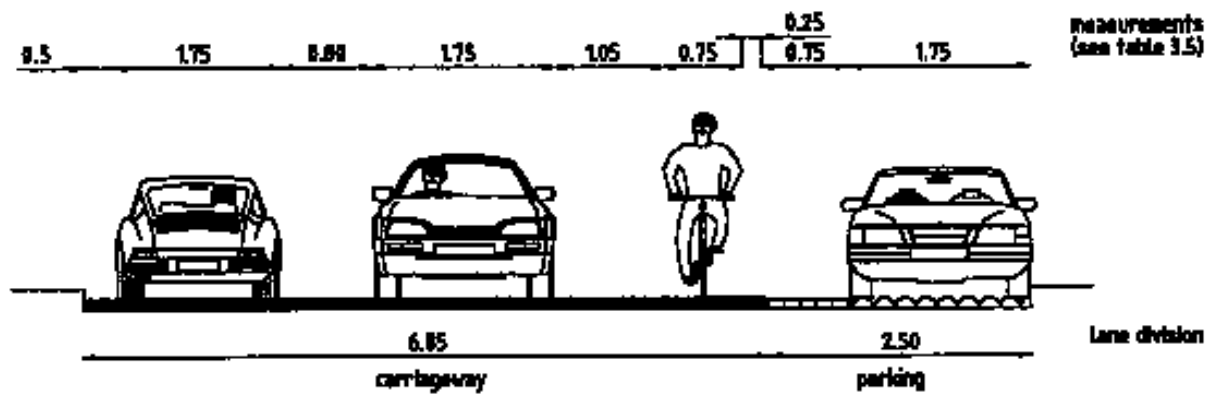

FIGURE 3.22 | ROAD WITH TWO-WAY TRAFFIC WITH A MAXIMUM SPEED OF 50 KM/H. A WIDE CROSS-SECTION FOR THE TYPICAL USE OF BICYCLE-CAR-CAR



3.10 Cyclists and pedestrians only

Where to apply

In shopping areas, residential areas and parks with access for pedestrians and cyclists only.

Specification (Table 3.6; 3.7)

- Always plan for two-way cycle traffic (it will be very hard to enforce one way cycle traffic in these situations).
- With low volumes of both cyclists and pedestrians, simple road-markings might be sufficient, but a well designed street lay-out is preferable.
- In shopping areas it is advisable to allocate an exclusive space to cyclists in the middle of the road, identified by a different pavement and/ or colour. During off-peak hours the track can also be used to give access for loading vehicles.

General comments

- A clear lay-out of car-free zones will promote an efficient flow of bicycle and pedestrian traffic, and make it clear what each mode can expect from the other.
- Careful attention should also be paid to the design and locations of cycle parking racks in these areas. Parked bicycles should not block the way for pedestrians.
- If the volume of both cyclists and pedestrians is high, they will impede each other when mixing. If pedestrians outnumber cyclists, then the cycle traffic will adjust its behaviour to that of the pedestrians. If cyclists outnumber pedestrians, then the pedestrians are more likely to give way to cyclists.
- In a street with shops on both sides, pedestrians need more lateral freedom of movement than on a route used for access.

TABLE 3.6: | TYPE OF SEGREGATION

Type of segregation	Where to apply
No segregation, only road signing	With low cycle and pedestrian volumes, in parks and along canals,
Road markings (white solid or broken line)	In parks, coastal routes, residential areas
Low kerb (height difference < 0.05m)	In parks, residential areas
Different surface material or colour	Residential areas, shopping areas
Bollards	Shopping areas with high volumes of pedestrians and cyclists, and particularly for use on street corners.

DIMENSIONS

TABLE 3.7 | WIDTHS (DO NOT APPLY TO FACILITIES AT BRIDGES OR ADJACENT TO CANALS) (FIG 3.23)

Width of the Track	Remarks
2.00 m	Minimum width, two people in a wheelchair can pass each other. If conflicts occur between pedestrians and cyclists additional measures should be applied to lower the speed of cyclists.
3.00 m	Preferable width.
3.00 - 5.00 m	Recommended for high volumes of pedestrians and cyclists.

(Irish volumes associated with these widths are not yet available)

FIGURE 3.23 | THE AMOUNT OF SPACE NEEDED BY CYCLISTS AND PEDESTRIANS

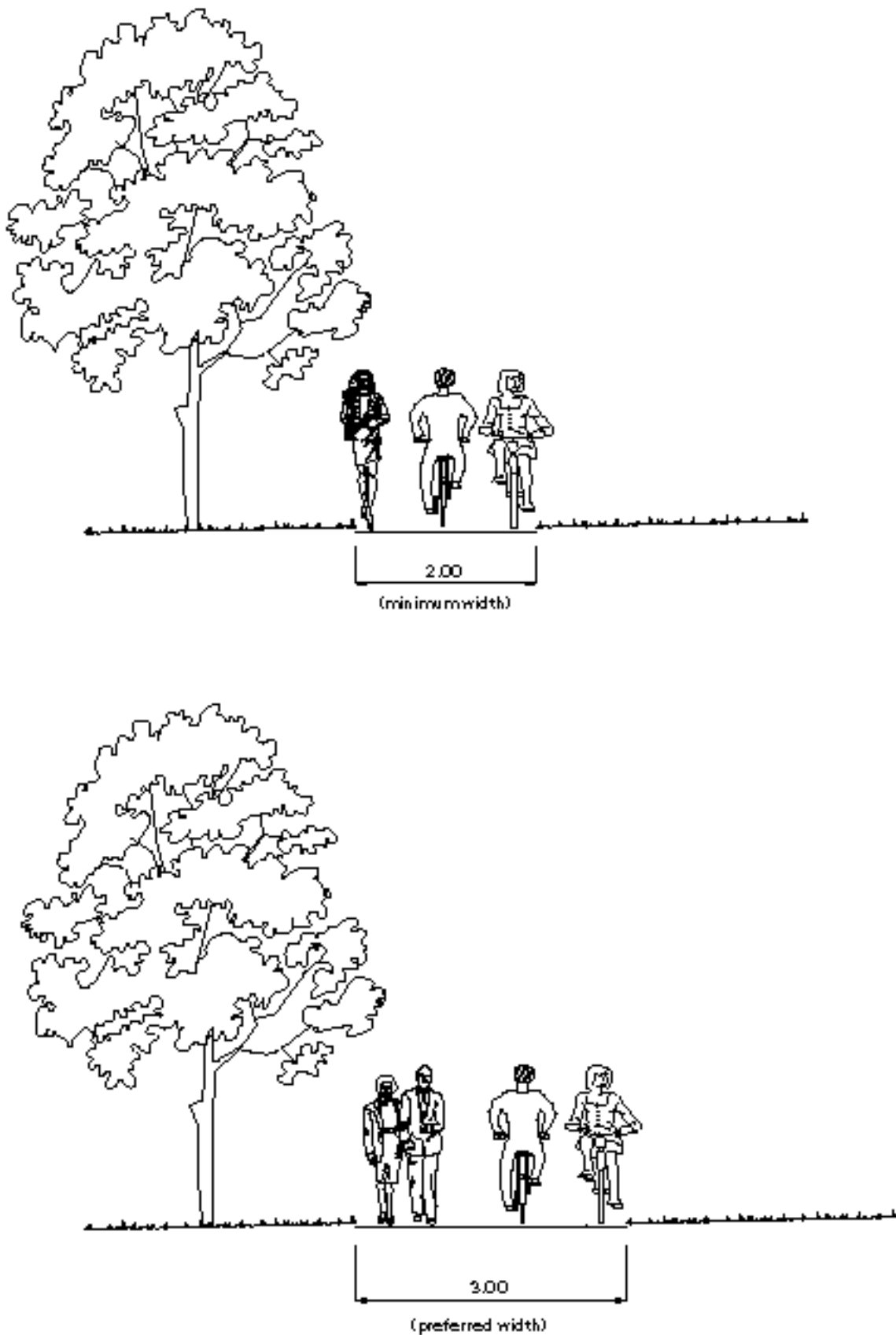

3.10.1 Cycle and pedestrian facilities at bridges, tunnels and towpaths (fig 3.24)

Where to apply

Always try to provide access to bridges and tunnels for both pedestrians and cyclists to avoid detours and to improve the quality of the cycle and pedestrian networks. This also applies to the provision of paths along canals and rivers.

Specification

- On narrow tracks (<2.00m) protection is needed at the edges. This can be a railing, attached to the side of the bridge.
- On towpaths a clearance of 1.50m is recommended for anglers. The verge at the waterside should be used for this.
- In tunnels the minimum height of the structure should be 2.5m. (see 3.1.1)

General comments

- The width of a track on a bridge can be widened by attaching a cantilevered section to the bridge. This construction can be made of steel and wood, or entirely of wood. If heavy vehicles (like cars) are not allowed on the cantilevered tracks, then construction costs will be less.
- Edges and narrow tracks in tunnels must be well lit.
- When the width of the bridge is too narrow for segregation, facilities to safely integrate cyclists and pedestrians should be provided. The main objective is to reduce the speed of cyclists to enable them to mix easily with pedestrians. An effective solution is a combination of two fences, one closely behind the other, across the walkway where pedestrians and cyclists will slalom through.

- Existing tunnels on towpaths can be very narrow and dark. A railing is recommended in order to improve safety and to reduce cyclists' speed.
- Narrow tunnels on towpaths should be avoided by using the exit and entrance tracks to the towpath. Cyclists will then use these parallel tracks (see photo fig 3.25). This is a good alternative, as long as the motorised traffic volumes using the road across the tunnel are low.

FIGURE 3.24 | FACILITIES AT A BRIDGE

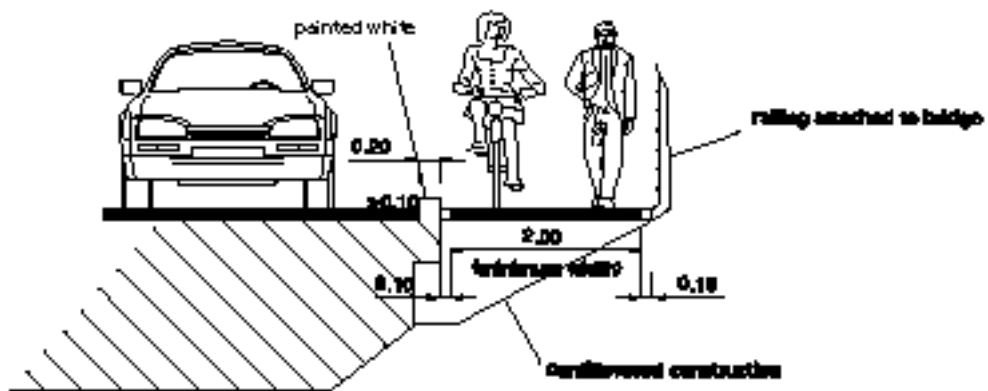
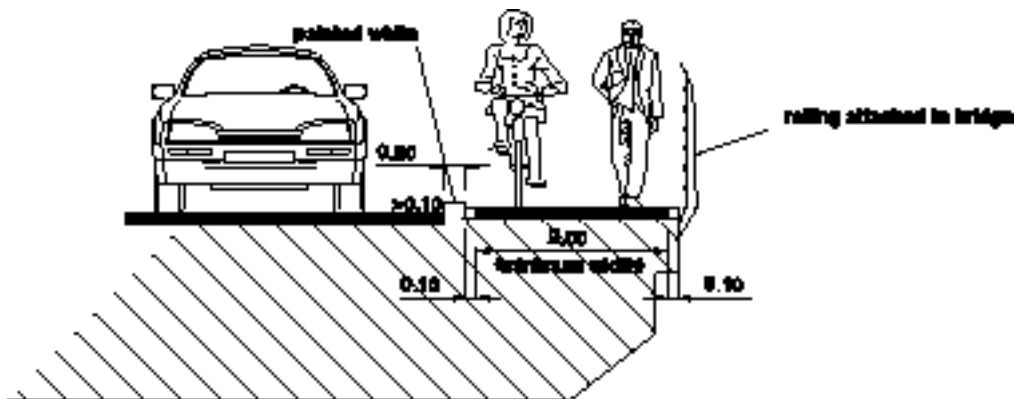

FIGURE 3.25 | ALTERNATIVE ROUTE FOR PASSING THE TUNNEL BY USING THE ENTRANCE TRACK (ON THE RIGHT SIDE) FROM AND TO THE TOWPATH



3.10.2 Cycle facilities along an LRT-line (fig 3.25)

Where to apply

In principle cycle facilities should always run parallel with the LRT-lines. (Related to the straight alignment of the LRT-lines cycle traffic will greatly benefit of these direct routes).

Transverse cycle routes should be linked with the LRT-lines and the main LRT-stops in a direct and comfortable way.

Specification

The following table gives an overview of the specifications for the different design elements which will have to be addressed when designing integrated cycle facilities with LRT-lines:

Measures (of the verge between the LRT-line and the adjacent cycle tracks)

To provide a feeling of safety and comfort the width between the LRT-line and the track should be related to the speed of the tram. The width between the adjacent cycle track and the LRT-line is preferably a minimum of 1.50m. In this situation the speed of the trams should not exceed 50 km/h. When the speed of the tram at sections is 80 km/h then the width of the verge should be 2.50m. If this width is not available then a railing between the LRT-line and the cycle track is required.

Legal status

All crossing traffic will have to give priority to the trams on the LRT-line. Cycle traffic running parallel to the LRT-line should benefit from the priority associated with the LRT-line.

Design element	Shape and specification
Cycle route running parallel to LRT-line	Cyclists will use the left hand side of the carriageway; therefore there will be sufficient room between the cyclists and the trams. Mixed use of pedestrian facilities: at first this should be avoided however exceptions are possible. For the conditions of mixing cyclists and pedestrians see § 3.10. Cycle track adjacent to the LRT-line: this can be a one way cycle track at both sides of the track or a two way cycle track at either one side or at both sides of the LRT-line.
Transverse cycle route to LRT-line	These routes should be carefully connected to the parallel (cycle) routes running along the LRT-line, preferably these connections should be integrated with the LRT (main) stops. Transverse cycle routes should have proper crossing facilities (see next line).
Crossing the LRT- line	Cyclist (and pedestrians) will at numerous locations need to cross the LRT-line. Preferably these crossing locations should be combined with the LRT-stops. Where high volumes of pedestrians and cyclist (> 50/hour in both directions) are crossing a warning light should be installed to indicate when crossing is not allowed because of an approaching tram. In practice a crossing will always be used in two ways therefore the width of the crossing cycle track should have a minimum of 3.00m. Waiting cyclists and pedestrians should have adequate space to wait before crossing, waiting cyclists should not block the road for straight going cyclists. A minimum width of 2.00m between the LRT and the road for parallel running traffic. When the volumes of crossing pedestrians and cyclists are high this width or the width of the crossing cycle track should be increased. At crossings at platforms this width should be to the platform width of 3.00m (see EIS volume 1)
Passing platforms	The platforms should always be between the LRT-line and the cycle track. At a double deck platform, adequate space of 2.00m must be provided for crossing pedestrians.

FIGURE 3.25 | CYCLE FACILITIES AND LRT FACILITIES

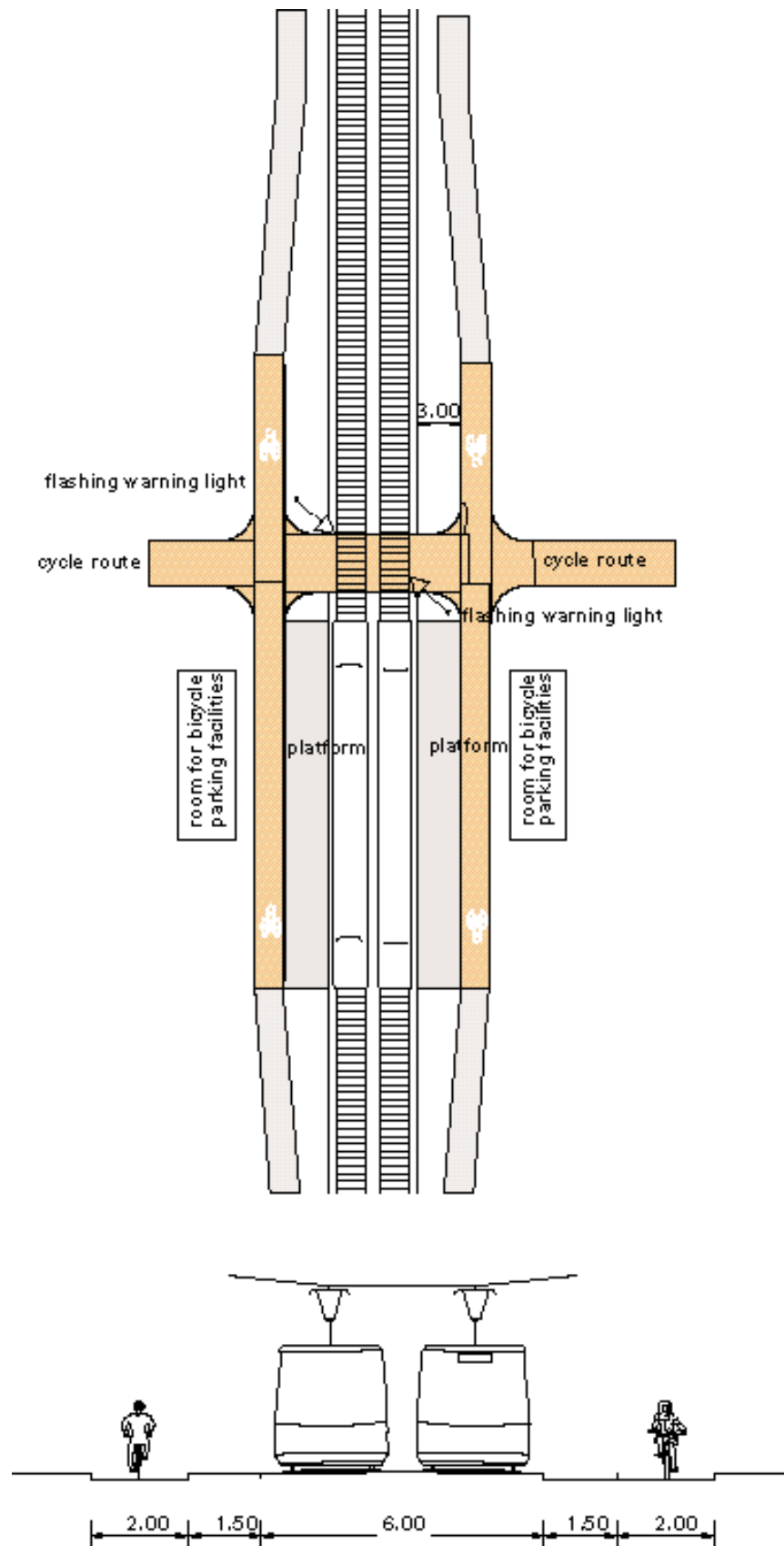

3.10.3 Cycling and public safety (fig 3.26)

Where to apply

These recommendations apply to all situations where cyclists might feel unsafe, for example cycle facilities through parks, forests, greenery along roads, or through remote urban areas.

Recommendations

The main objective is to maintain or improve the attractiveness (main requirement) of the routes.

- Cycle tracks must be well-lit if used at night time.
- There should be no high bushes directly adjacent to the cycle route. Grass, plants, creepers and trees can be used.

Figure 3.26 shows how vegetation along cycle routes should look.

- Obscure corners are undesirable.
- Good design of tunnels and viaducts is essential.
- Direct and easily accessible cycle routes are used most. The more people, the less danger there is. In addition it is important that cyclists can spot 'escape routes' in good time.
- Regular maintenance (cleaning, replacement of damaged/destroyed objects, pruning) is desirable.
- There should be extra police surveillance at locations which are well-known trouble spots.

General comments

- Public safety is inextricably linked with the design of urban space, but unfortunately it cannot be completely guaranteed even with good design.
- Public safety should, as far as possible, be built into the design of cycle routes.
- The best way to identify the unsafe locations is by inspecting the routes by day and by night. The users, local authorities, planners and designers can then discuss the problems together, and put forward solutions.

FIGURE 3.26 | THE SHAPE OF VEGETATION ALONG A CYCLE TRACK CAN MAKE A BIG DIFFERENCE TO PUBLIC SAFETY

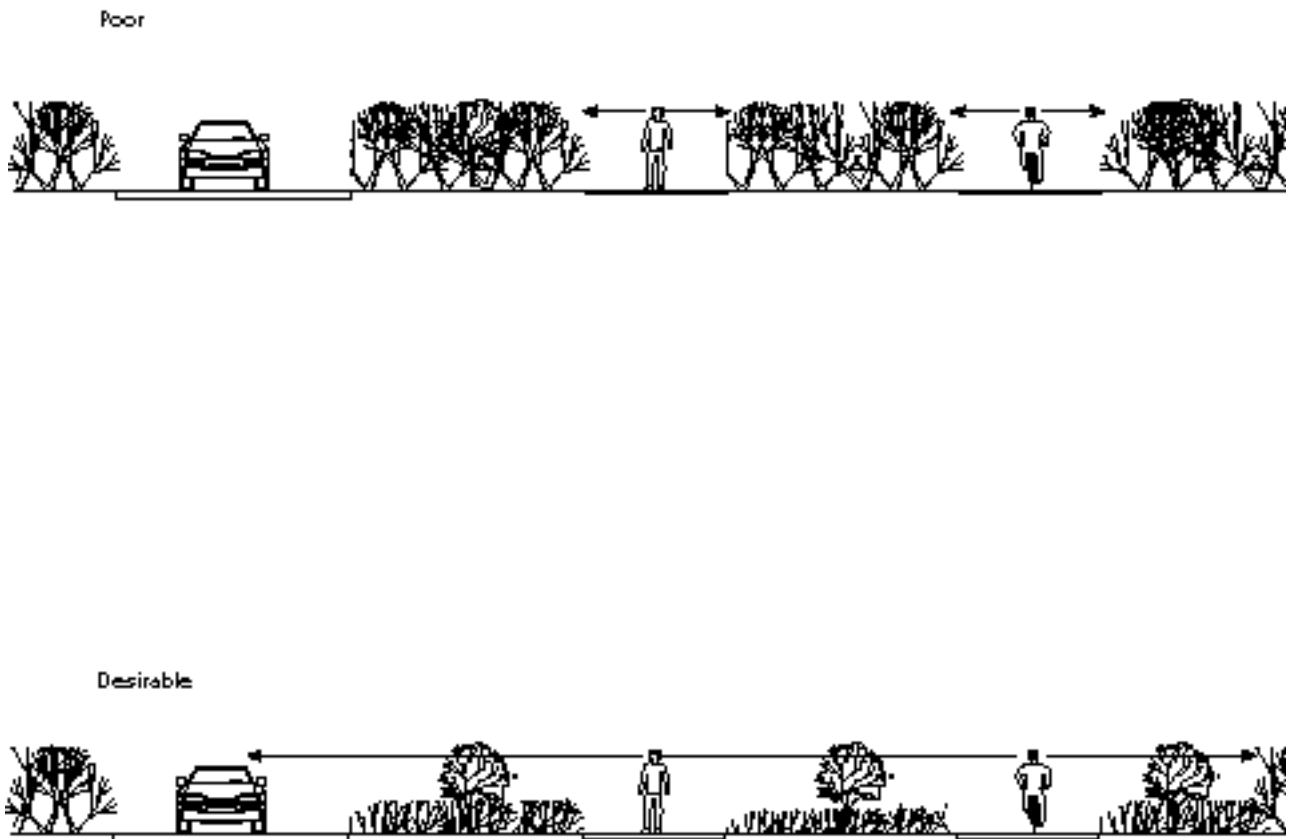



Cycle Facilities (Holland)